



ALGEMENE KENMERKEN:

Type: Lug
 Huis in nodulair gietijzer, Rilsan gecoat (230µ ~ 300µ / C5M) RAL 1016
 Inbouw lengte: ISO 5752
 Flens: DIN PN 10/16 (vanaf DN 32 tot DN 150)
 DIN PN 10 (vanaf DN 200 tot DN 400)
 Opbouw flens: ISO 5211
 De klep kan om de 10° worden vastgezet.
 > DN 250: wormkast

BEDRIJFSOMSTANDIGHEDEN:

Voor drukken tot 16 bar (10 bar vanaf DN 250)
 en temperaturen van -10 °C tot 90 °C

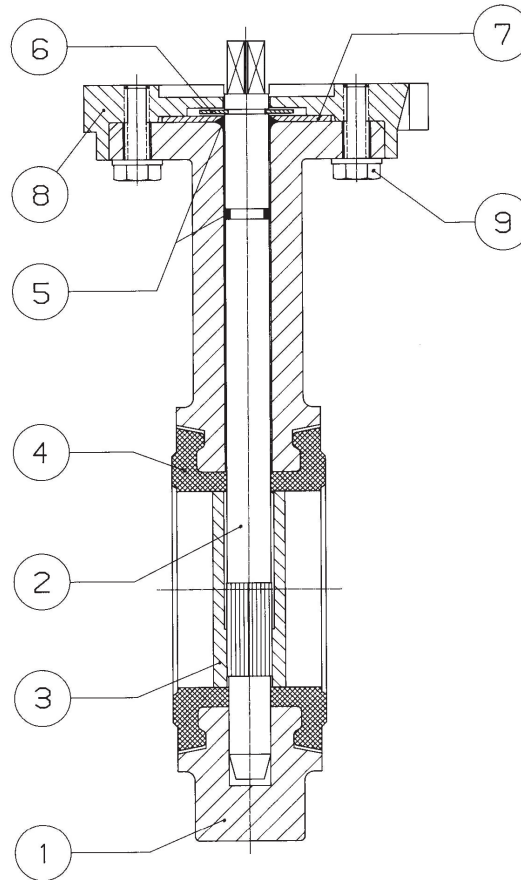

ONTWERP	
Vlinderklep	ISO 5752, API 609
Volgens	DIN 3202, API 609, BS EN 558
Opbouw flens	ISO 5211
Markering	ISO 5209
TESTEN EN CERTIFICATEN	
PED/CE	2014/68/EU
Druktest	EN 12266-1

MATERIALEN:

Pos.	Omschrijving	Materialen
1	Huis	Nodulair gietijzer GJS-500-7 RAL 1016 (geel)
2	Spindel	Roestvrijstaal AISI 420
3	Klep	Roestvrijstaal AISI 316
4	Zitting	Buna gas, gelijmd
5	O-ring	Nitril rubber
6	Circlip	Staal
7	Washer	Staal
8	Opbouwflens	Aluminium
9	Bout	DIN 933 5.6
10	Hendel	Aluminium RAL 1016 (geel), bout in DIN 933 5.6

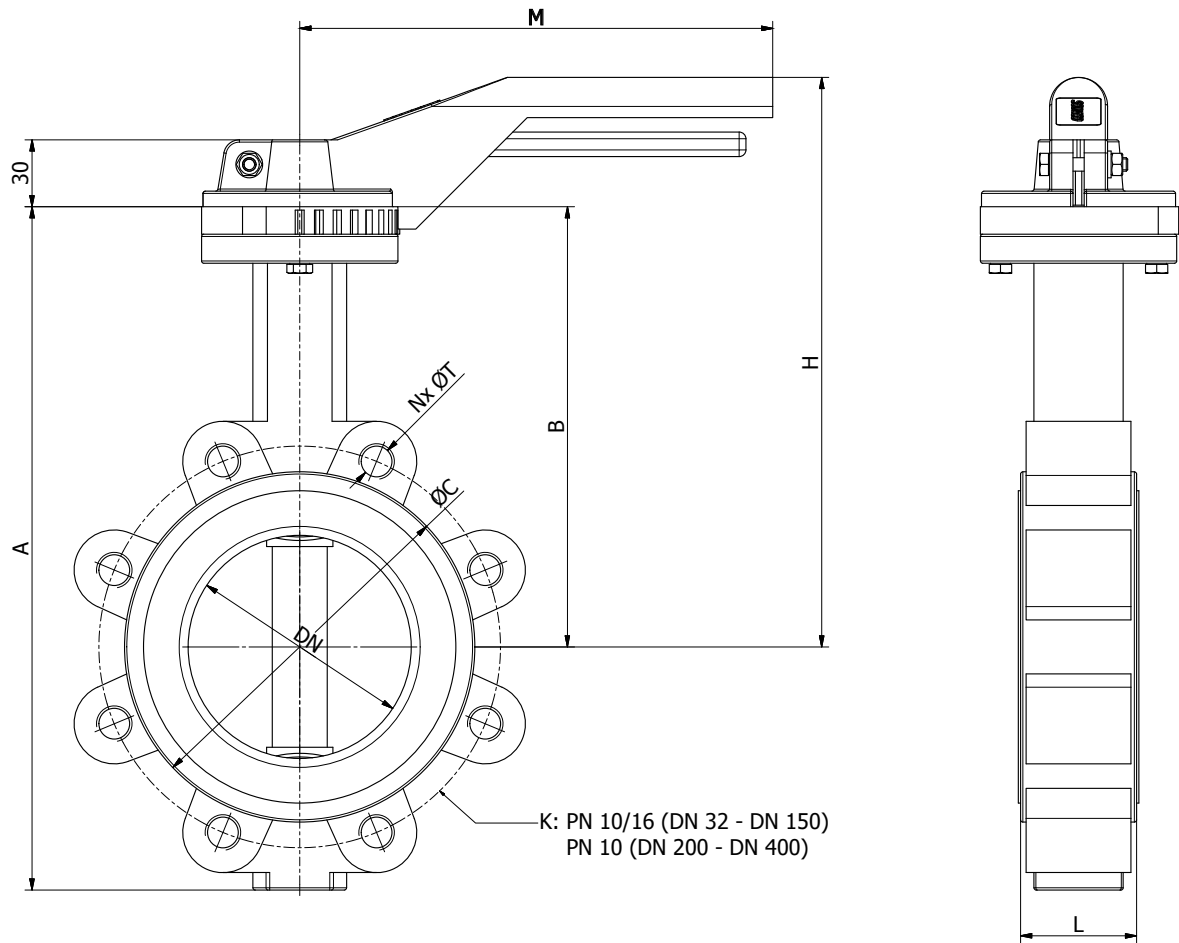

AFMETINGEN: (mm)

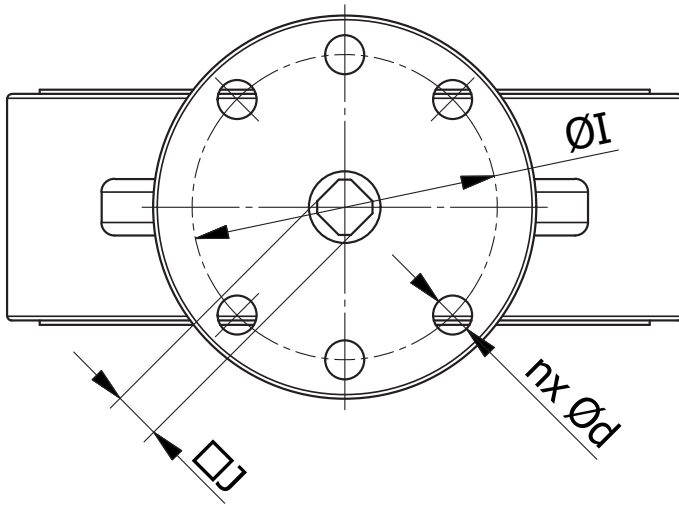
DN	Ø	A	B	C	L	M	H	PN 10		Kg
								K	N x T	
32	1 1/4"	205	140	82	33	212	198	100	4x M16	3,0
40	1 1/2"	205	140	82	33	212	198	110	4x M16	3,0
50	2"	226	156	102	43	212	214	125	4x M16	3,5
65	2 1/2"	246	161	119	46	212	219	145	4x M16	4,5
80	3"	259	169	135	46	212	229	160	8x M16	5,5
100	4"	295	187	155	52	212	241	180	8x M16	8,0
125	5"	325	206	185	56	329	279	210	8x M16	11,0
150	6"	352	215	208	56	329	287	240	8x M20	12,0
200	8"	422	255	270	60	329	327	295	8x M20	18,5
250	10"	460	248	328	68	610	290	350	12x M20	28,5
300	12"	523	280	381	78	610	325	400	12x M20	42,0
350	14"	570	300	437	78	-	-	460	16x M20	53,0
400	16"	644	340	486	102	-	-	515	16x M24	77,0

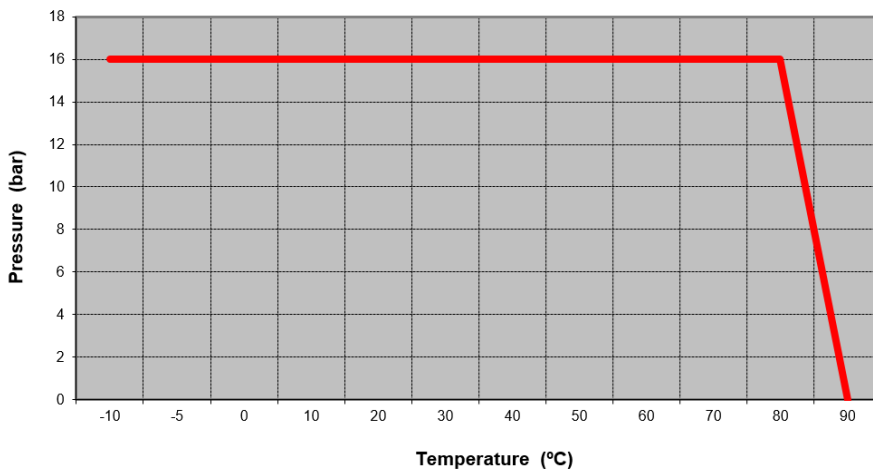

DN	Ø	ØI	nx Ød	J	ISO5211
32	1 1/4"	70	4x 9	8	F05 - F07
40	1 1/2"	70	4x 9	8	F05 - F07
50	2"	70	4x 9	8	F05 - F07
65	2 1/2"	70	4x 9	9	F05 - F07
80	3"	70	4x 9	11	F05 - F07
100	4"	70	4x 9	11	F05 - F07
125	5"	70	4x 9	14	F07
150	6"	70	4x 9	14	F07
200	8"	70	4x 9	17	F07
250	10"	102	4x 11	19	F10
300	12"	102	4x 11	22	F10
350	14"	140	4x 18	22	F14
400	16"	140	4x 18	27	F14

DRUK - TEMPERAATUUR:



Kv-WAARDEN, LOSBREEKMOMENT:

DN	Ø	Kv (m³/h)	T (Nm)
32	1 1/4"	70	9
40	1 1/2"	70	9
50	2"	111	11
65	2 1/2"	201	20
80	3"	335	29
100	4"	552	47
125	5"	901	82
150	6"	1427	130
200	8"	2392	210
250	10"	3826	360
300	12"	5660	475
350	14"	8179	760
400	16"	10660	1300

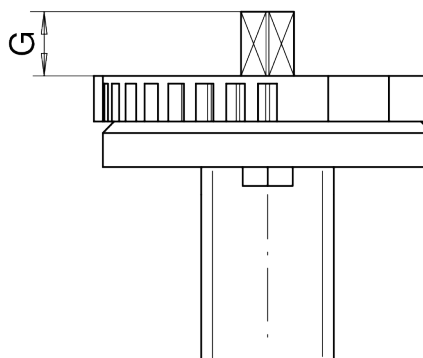

HOOGTE VRIJE AS:

DN	G
32	14
40	14
50	14
65	16
80	16
100	20
125	20
150	20
200	24
250	24
300	24
350	29
400	29

De aangeduide waarden zijn geldig voor water bij omgevingstemperatuur