



**RICHTER**  
Process Pumps & Valves

KN, KNA, KNR, KNAR, KA-N, KK

# HEAVY-DUTY BALL VALVES

SHUT-OFF, CONTROL &  
DRAIN VALVES

- ✓ SUPERIOR CORROSION RESISTANCE
- ✓ RELIABLE DESIGN
- ✓ MAINTENANCE-FREE ENVIPACK STEM SEALING
- ✓ -60 TO +200 °C  
(-75 TO +400 °F)

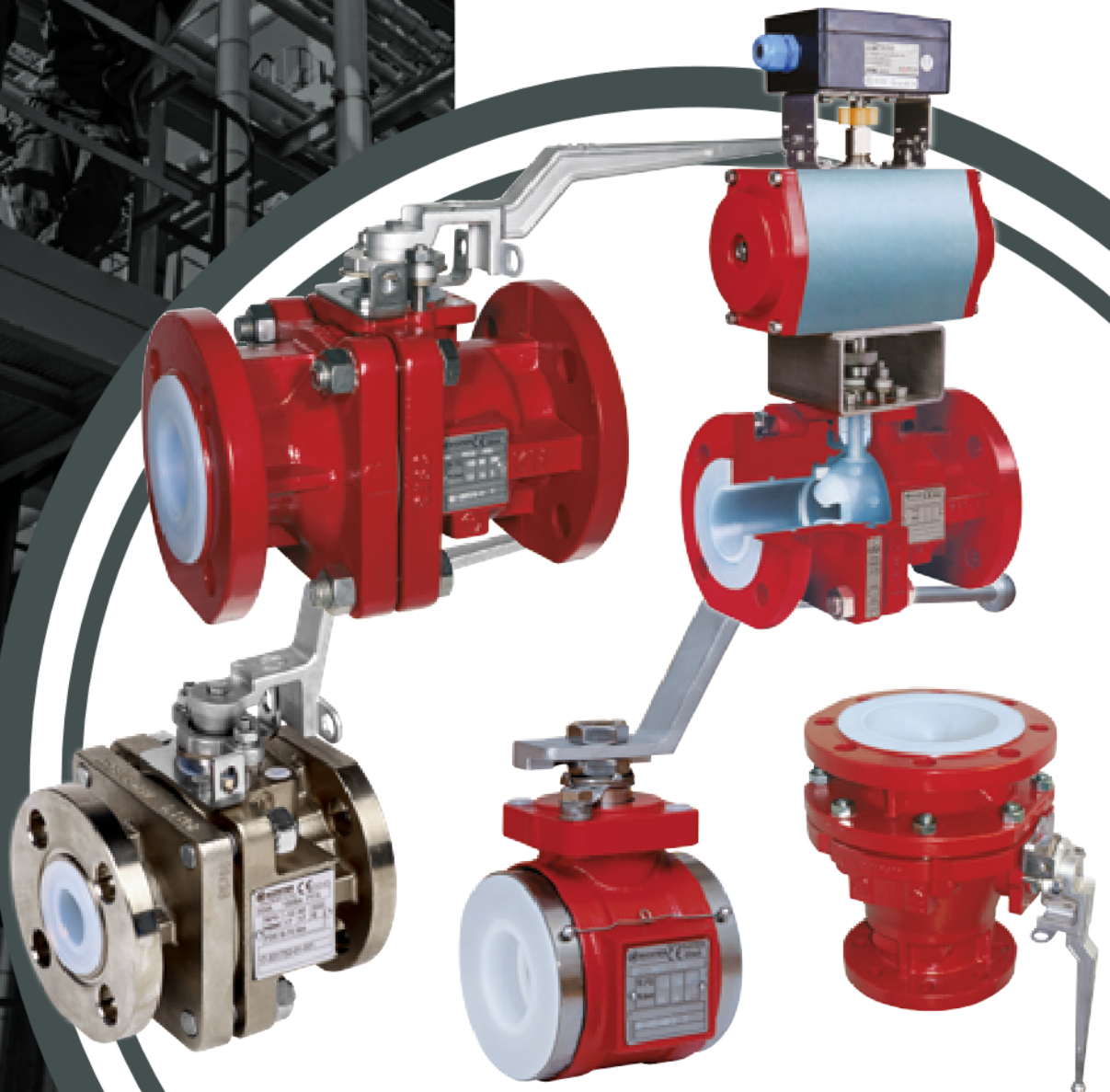

## Heavy duty ball valves with ENVIPACK stem sealing

The ball valve family, KN, excels by offering problem solutions from a modular system. The selection of fluoroplastic linings, the large temperature/pressure range and the numerous options permit a tailor-made solution for virtually every application involving highly corrosive and ultrapure media – with more or less the same components!

### The standard KN/KNA modular system:

1 ISO/DIN + 1 ASME/ANSI body, 2 lining materials, 1 universal stem sealing, 4 standard ball versions.

In addition, Richter's speciality: customised special solutions.

### The ball valves of the KN/KNA family are

- Shut-off and control valves for highly aggressive fluids
- For applications where stainless steel, special metals and standard plastics are not sufficiently corrosion-resistant
- the cost-effective and readily available alternative to special metals
- Suitable for pure, ultrapure and solids-laden media

### Product features

- 1-piece, PFA-lined ball/stem, optionally Al<sub>2</sub>O<sub>3</sub> ball and special versions
- DN 15-200 and 1/2"-8", full bore
- DN 200 optional with reduced bore
- Optional manufacturer's declaration to TRwS ATV-DWVK-A 780, part 1, design A
- optional: type-test approval mark according to DIN EN 14432

Type codes	manual actuation		remote actuation	
	Shut-off valve	Control valve	Shut-off valve	Control valve
• ISO/DIN	KN/...	KNR/...	KNP/...	KNRP/...
• ASME/ANSI short	KNA/...	KNAR/...	KNAP/...	KNARP/...

### Lining

- PFA .../F
- Antistatic PFA-L .../F-L

Ball valve series selection, Outline of the features that can be configured

Options	KN	KNA	KNR	KNAR	KA-N	KK
ISO/DIN face to face, flanges PN 16 ① / ISO/DIN face to face, flanges PN 25 (DN 25-80)	•/•		•/•		②	③
ASME/ANSI short face to face, flanges Cl. 150 ①		•		•		
Shut-off/control	•/-	•/-	•/•	•/•	•/-	•/-
ENVIPACK bellows-type packing	•	•	•	•	•	
Operating temperature up to 150 °C/200 °C (-20 °F/400 °F)	•/•	•/•	•/•	•/•	•/•	•/-
Operating temperature down to -29 °C/-60 °C (-20 °F/-75 °F)	•/•	•	•/•	•	•/•	•/•
Vacuum applications	•	•	•	•	•	•
Solids-containing fluids ④	•	•	⑤	⑤	•	•
Ultrapure media	•	•	•	•	•	
TF ball/stem for optimum drainability	•	•			•	
Low-cavity	•	•	•	•	•	•
Lining pure PFA, min. 3,5 mm/min. 5 mm (1/16" 1/8")	•/•	•/•	•/•	•/•	•/•	•/-
Lining antistatic PFA-L	•	•	•	•	•	•
One-piece PFA-lined ball/stem	•	•	•	•	•	
PFA-lined ball, separate stem						•
Al <sub>2</sub> O <sub>3</sub> ceramic ball, separate stem	•	•			•	•
Body ductile cast iron	•	•	•	•	•	•
Body stainless steel ISO/DIN (DN 25-80)	•					
ASME/ANSI (1"-2")		•		•		

### ① min. 3.5 mm (1/16") thick lining made of pure PFA

- High permeation resistance
- Vacuum-proof anchoring
- transparent, optimal quality assurance,
- **minimal 5 mm (1/8") wall thickness option** (≥ DN 25/1)
- Optional antistatic lining

### ② Body made of ductile cast iron

EN-JS 1049/ASTM A395, absorbs the system and pipe forces

DN 25 up to DN 80 respectively ASME/ANSI 1"-2" also available in stainless steel (1.4408)

### ③ Permanently tight body connection

- Also with frequent temperature changes
- Full lining (3a)
- Body halves center themselves exactly to each other owing to the fit (3b)
- Labyrinth-like sealing (3c): maximum surface pressure between the body halves
- „Almost metallic stop“ (3c) absorbs pipe forces (see page 3)

### ④ Different ball versions (see page 3)

- Standard one-piece ball/stem with lining and stainless steel core
- Eliminates the fits of 2-piece plastic-lined ball/stem versions which are less load-bearing
- Thus optimising operational reliability

### ⑤ Resilient PTFE seat rings: spring loaded

Permanent pretension of the ball, gas-tight seal

### ⑥ Richter ENVIPACK stem sealing with active stainless steel packing gland follower (6a)

- Conformity with German Clean Air Act (TA Luft), self-adjusting
- Bellows-type packing insert (6b), gas-tight to EN 12266 leakage rate A
- Virtually maintenance-free sealing even with frequent hot/cold cycles
- Visual inspection of the pre-tensioning action
- Can be re-adjusted from outside in a controlled manner (6c)

### ⑦ Universal ISO 5211 connection

### ⑧ External corrosion protection

Epoxy coating. Stuffing box, lever, screws/nuts made of stainless steel

① On request, flanges drilled to ASME Cl.150

② Special face to face, see tables on page 7

③ Flangeless compact design, face to face = DN + 50 mm

④ Solids: in general, consultation with manufacturer recommended

⑤ Limited suitability

Thick-walled lining,  
4 ball versions

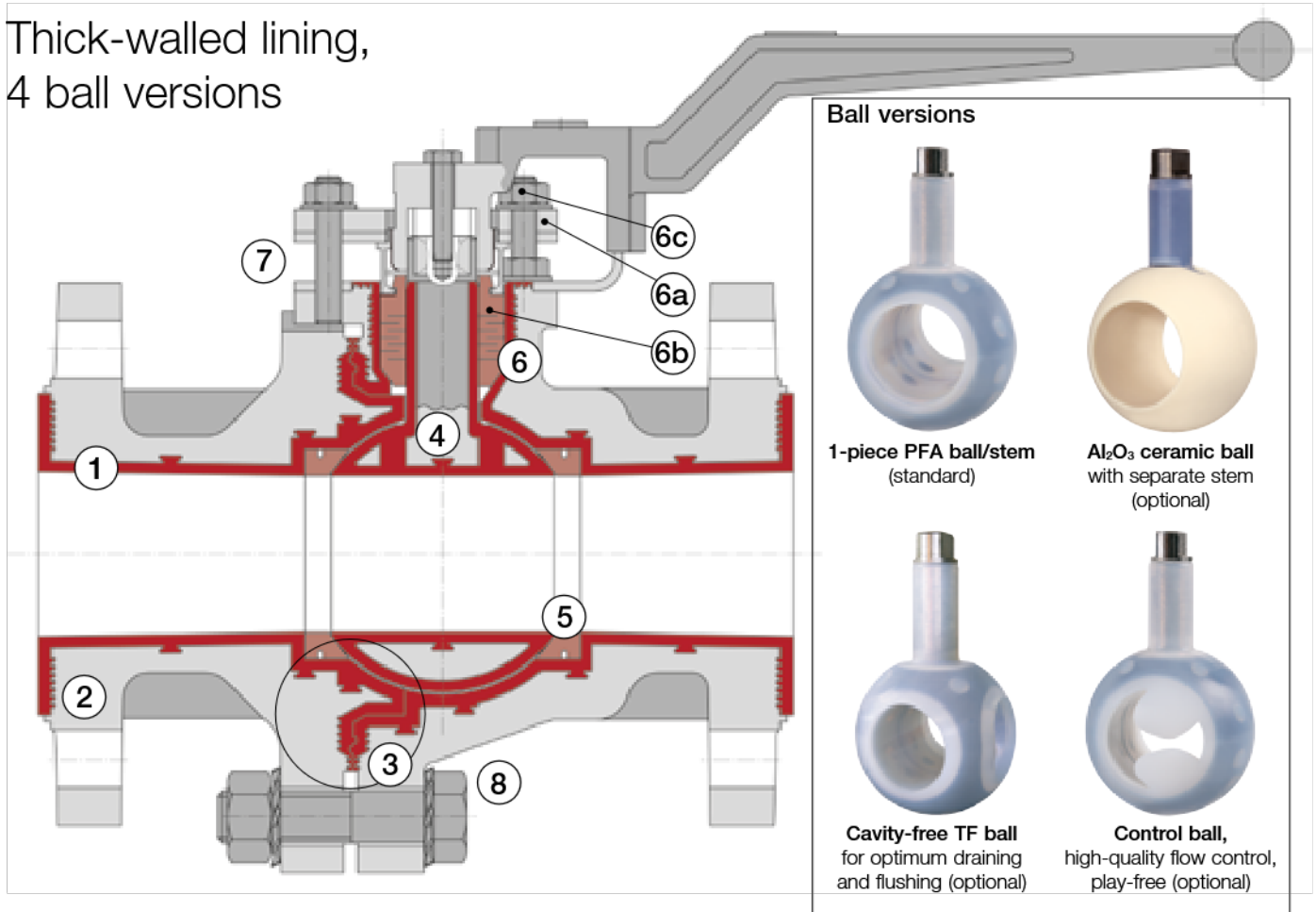

Why does Richter rely on “almost metallic stop” instead of “metallic stop”?

Richter’s “virtually metal-to-metal contact”, permanently tight:

The body lining (3d) decreases to about 0.5 mm (0.02) permitting the inner flange connection to be retightened in the event of a leak in the sealing area. However, leakage is highly improbable thanks to the labyrinth-type design (3c) typical of Richter.

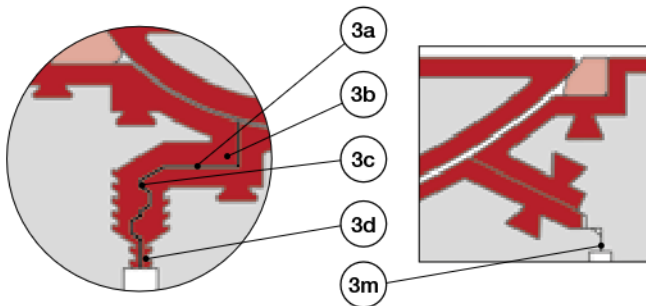

What are the disadvantages of lined valves with “metallic stop”?

The body halves are bolted together with full metallic contact (3m). Retightening is not possible, any leak that occurs cannot be stopped. The cavity between the lining and the metallic contact also prevents the early detection of any leak.

Pressure/temperature range

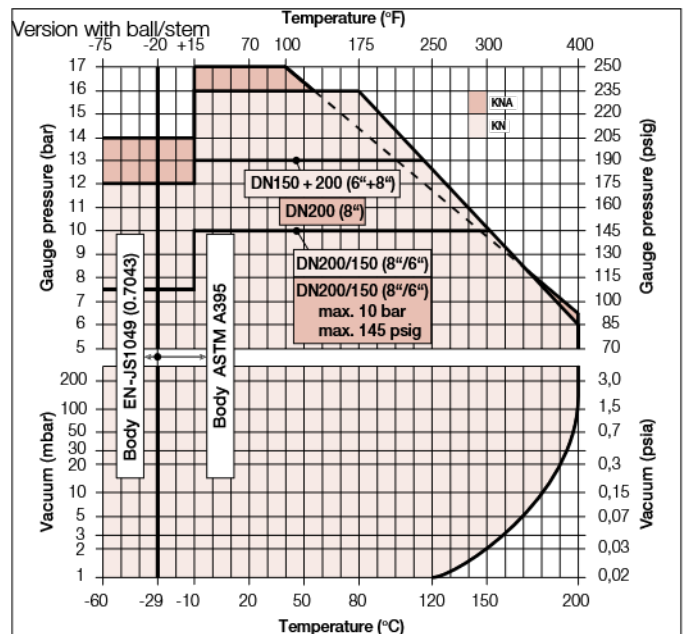

Body EN-JS 1049 (0.7043)/PFA:  
-60 °C (-75 °F) to +200 °C (400 °F); max. 16 bar (235 psi)  
acc. to AD 2000

Body ASTM A395/PFA:  
-29 °C (-20 °F) to +200 °C (400 °F); max. 17.2 bar (250 psi)  
acc. to ASME B16.42

For applications at low temperatures, please observe the local regulations!

## Richter drain valves KA-N with ENVIPACK stem sealing

Drain valves are compact, sturdy vessel drain valves and much lower-priced than sliding stem valves.

The KA-N has – apart from the tapered inlet nozzle – the same design as the ball valve series KN.

The pressure/temperature range, design features, material range and the major spare parts are identical.

### Product features

- Full bore
- DN 50/25 (Ø 24,5 mm) to 150/100 (Ø 96 mm), 2 1/4" (Ø 1") to 8 7/8" (Ø 6")
- -60 to +200 °C (-75 to +400 °F), see diagram on page 3
- Face-to-face: see table on page 7
- Flanges ISO/DIN 7005-2 PN 16, on request, drilled to ASME B16.05 class 150

### Other options:

- Body heating jacket, stem extension

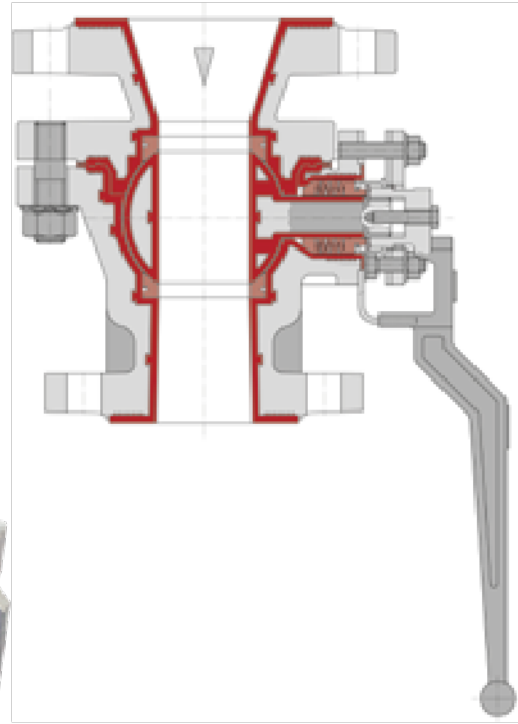

### Common features of the series KA-N, KNA-S and KNR/KNAR

- Labyrinth-like, permanently tight body connection
- Lining 3.5 mm (1/7") virgin PFA, optionally PFA-L antistatic
- Self-adjusting, maintenance-free ENVIPACK stem sealing
- Resilient seat rings, gas-tight in the seat
- Conformity with the German Clean Air Act
- Lockable stainless steel lever
- Actuator mounting to ISO 5211, optionally head flange to ISO
- Low-cavity as standard feature
- One-piece PFA ball stem, optionally Al<sub>2</sub>O<sub>3</sub> ceramic ball with separate stem, cavityfree TF ball, all blowout-proof
- Or control ball with high-quality control performance for KNR and KNAR valves

## PFA lined stainless steel shut-off and control valves

The PFA-lined stainless steel KNA-S and KN-S are predestined for the shut-off and control of corrosive fluids

- in clean-room environments where high-quality exterior surfaces without paint are preferred
- in corrosive atmospheres, e. g. in HF, HNO<sub>3</sub> and pickling plants
- in processes where the fluid itself must not come into contact with ductile cast iron if the lining is damaged.

The pressure/temperature range as well as the components balls, seat rings, stem sealing and valve actuation correspond to those of the KN and KNA series, see page 3.

### Product features

- Precision cast stainless steel 1.4408 (316, CF8M), lining PFA
- Full bore flow
- ISO/DIN (DN 25 to DN 80) ASME/ANSI (1" to 2"), other nominal sizes on request
- from -29 to +200 °C (-20 to +400 °F) for KNA series  
from -60 to +200 °C (-75 to +400 °F) for KN series, see diagram on page 3
- Very low temperatures down to -200 °C (-330 °F) on request
- Face-to-face acc. to ASME/ANSI 16.10/short, face-to-face ISO/DIN on request



## Richter control valves KNR and KNAR with play-free torque transmission

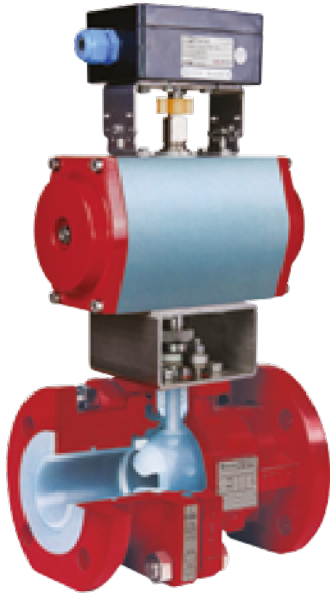

With the series KNR (ISO/DIN) and KNAR (ASME/ANSI) compact control valves with high control accuracy are available to plant operators. The KNR/KNAR valves are in many applications a very economical alternative to bellows-type, sliding stem valves.

Valve bodies, seat rings and the ENVIPACK stem sealing are identical to those of the shut-off valves KN and KNA as are the selection of material and the pressure/temperature range. Advantages: minimum stock of spare parts, conversion from shut-off to control valve possible.

Weitere Informationen siehe separate Druckschrift.

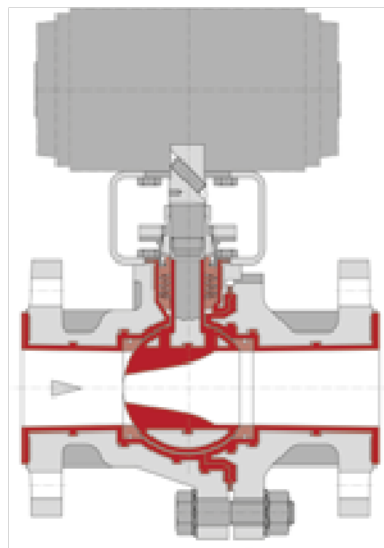

### Product features

- Up to 8 finely graduated  $k_{vs}/C_v$ -values per nominal size
- Equal percentage characteristic acc. to DIN EN 60534, linear by means of positioner
- DN 15 to 200 ( $1/2"$  to 8")
- -60 to +200 °C (-75 to +400 °F), see diagram on page 3
- Face-to-face according to
  - ISO/DIN 5752 R.1 (apart from DN 200)
  - ASME/ANSI B 16.10/8, Cl.150
- Flanges to
  - ISO/DIN 7005-2 PN 16 (DN 200/150 8"/6": PN 10), DN 25-80 (1"-3")
  - ASME B16.5 Cl.150

### Other options:

- Extra thick body lining: 5 mm ( $1/5"$ ) PFA for permeating media

## Richter flangeless compact ball valves KK

### Product features

- Lining 3.5 mm ( $1/8"$ ) virgin PFA
- Body of ductile cast iron EN-JS 1049 (ASTM A395)
- DN 25-150 (1"-6"), PN 16 (DN 150 (6") = PN 10)
- Full bore with DN 25-50 (1"-2"), reduced bore with DN  $\geq 65$  ( $2\frac{1}{2}"$ )
- -60 to +180 °C (-75 to +360 °F)
- Flangeless, face-to-face: DN+50 mm (2"), e. g. DN 50 (2") = 100 mm (4")
- PFA ball with separate stem,  $Al_2O_3$  ceramic ball option, blowout-proof
- Self-adjusting, maintenance-free stem sealing
- Resilient seat rings, gas-tight in the seat
- Conformity with German Clean Air Act
- DIN EN 14432 Dangerous goods certified to "dangerous goods" GGVSE/ADR/RID ch. 6.8
- Stainless steel lever
- Actuator mounting to ISO 5211
- Stainless steel grounding rope

### Other options:

- Stem extension

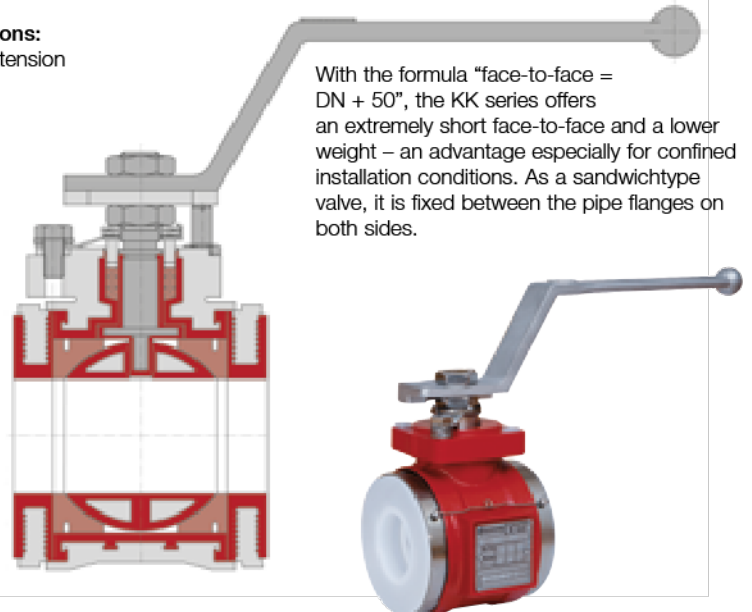

With the formula "face-to-face = DN + 50", the KK series offers an extremely short face-to-face and a lower weight – an advantage especially for confined installation conditions. As a sandwichtype valve, it is fixed between the pipe flanges on both sides.

# KN, KNA, KNR, KA-N, KK

Components and materials, operating torques, kv/Cv-values

## Components and materials

Item	Designation	Material
101	Main body	Ductile cast iron EN-JS1049 (ASTM A395), PFA-lined optionally PFA-L
102	Body end piece	Ductile cast iron EN-JS1049 (ASTM A395), PFA-lined optionally PFA-L
109	Transition cover	Stainless steel/PTFE
200	Ball	Al <sub>2</sub> O <sub>3</sub> 99,7 %
200	Ball (only KK)	Al <sub>2</sub> O <sub>3</sub> 99,7 %, stainl. steel/PFA
201	Ball stem unit	Stainless steel, PFA-lined optionally PFA-L
202	Stem	Stainless steel
203	Lever*	Stainless steel
401	Seat rings	PTFE (opt. Al <sub>2</sub> O <sub>3</sub> ball: mod. PTFE)
402/1	Packing ring	PTFE
403	Packing bellows	PTFE
405/1	Thrust ring	Stainless steel
422	Base lever	Modified PTFE
502	Spring gland follower	Stainless steel
503	Packing gland follower	Stainless steel
504	Cup spring assembly	Stainless steel
510	Bracket	Stainless steel
512	Sleeve nut	Stainless steel
526	Retaining washer	Stainless steel
532	Grounding rope	Stainless steel
557	Grounding spring washer	Stainless steel
577	Lever stop	Stainless steel
804	Coupling, play-free	Stainless steel
850	Actuator	to customer request
904/4	Setscrew	Stainless steel
w/o.	Screws and nuts	Stainless steel

\* a worm gear is recommended for torques >= 200 Nm (1770lbs)

All torques: Test medium water 20 °C, seat rings of pure PTFE. The torques may vary depending on the medium (dry gases, crystallising media, oil contents etc.)

## Series KN, KNA, KNR, KNAR

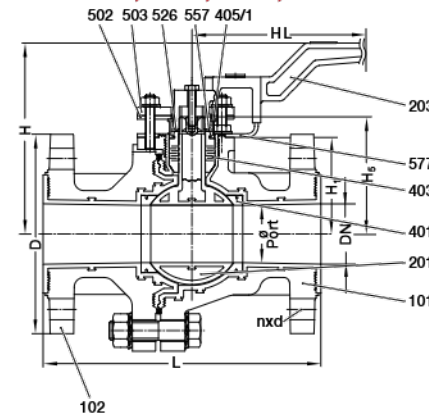

## Play-free coupling for KNR, KNAR

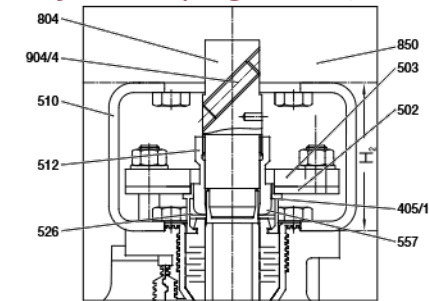

## Series KA-N

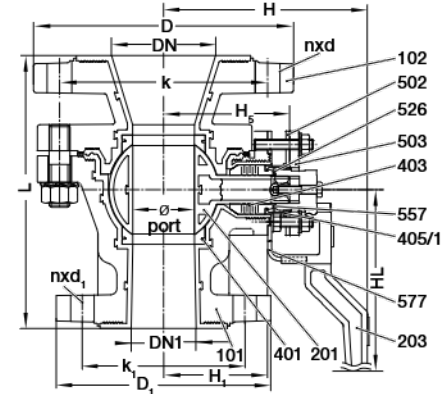

## Series KK

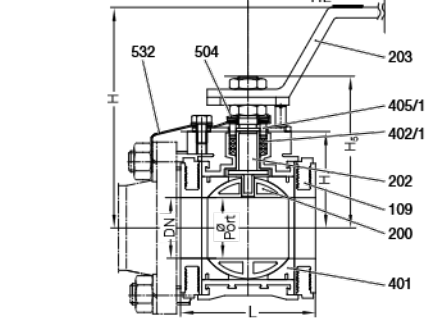

## KK: Operating torques (incl. breakaway torques) with PFA-lined or with Al<sub>2</sub>O<sub>3</sub>-ball

DN	Operating torques										max. admissible		
	Δp 3 bar		Δp 6 bar		Δp 10 bar		Δp 16 bar						
mm	inch	Nm	in-lbs	Nm	in-lbs	Nm	in-lbs	Nm	in-lbs	Nm	in-lbs	Nm	in-lbs
25	1"	7	62	7	62	7	62	7	62	7	62	20	177
40	1 1/2"	15	133	15	133	15	133	18	159	50	443	50	443
50	2"	15	133	15	133	15	133	18	159	50	443	50	443
65	2 1/2"	15	133	15	133	15	133	18	159	50	443	50	443
80	3"	40	354	40	354	42	372	50	443	120	1062	120	1062
100	4"	60	531	60	531	64	566	80	708	250	2213	250	2213
150	6"	100	885	113	1000	180	1593	-	-	500	4425	500	4425

## k<sub>v100</sub>/Cv-values\*

KK*	
k <sub>v100</sub>	Cv
m <sup>3</sup> /h	USgpm
51	59
150	175
248	289
300	350
455	530
830	967
1270	1480

## KN, KNA, KNR, KNAR, KA-N: Operating torques (incl. breakaway torques) with PFA-lined ball

KN, KNA, KNR, KNAR		KA-N		Operating torques									
DN		DN/DN1		Δp 3 bar		Δp 6 bar		Δp 10 bar		Δp 16 bar		max. admissible	
mm	inch	mm	inch	Nm	in-lbs	Nm	in-lbs	Nm	in-lbs	Nm	in-lbs	Nm	in-lbs
15	1/2"	-	-	8	71	8	71	8	71	10	89	70	620
20	3/4"	-	-	8	71	8	71	8	71	10	89	70	620
25	1"	50/25	2 1/4"	12	106	12	106	12	106	12	106	70	620
40	1 1/2"	-	-	20	177	20	177	20	177	25	221	225	1990
50	2"	80/50 + 100/50	3 1/2" + 4 1/2"	25	221	25	221	25	221	30	266	225	1990
80	3"	-	-	60	531	60	531	65	575	80	708	500	4425
100	4"	150/100	6 3/4"	80	708	80	708	90	797	170	1505	500	4425
150	6"	-	-	200	1770	250	2213	350	3098	-	-	2200	19470
200/150	8 7/8"	-	-	200	1770	250	2213	350	3098	-	-	2250	19913
200	8"	-	-	600	5310	600	5310	700	5310	-	-	2200	19470

## k<sub>v100</sub>/Cv-values\*

KN, KNA, KA-N*	
k <sub>v100</sub>	Cv
m <sup>3</sup> /h	USgpm
17,5	20
31	36
75	87
200	233
310	361
800	932
1250	1456
2800	3262
3200	3728
6000	6990

## KN, KNA, KA-N: Operating torques (incl. breakaway torques) with Al<sub>2</sub>O<sub>3</sub> ball

KN, KNA		KA-N		Schaltmomente									
DN		DN/DN1		Δp 3 bar		Δp 6 bar		Δp 10 bar		Δp 16 bar		max. admissible	
mm	inch	mm	inch	Nm	in-lbs	Nm	in-lbs	Nm	in-lbs	Nm	in-lbs	Nm	in-lbs
15	1/2"	-	-	10	89	10	89	10	89	12	106	28	248
20	3/4"	-	-	10	89	10	89	10	89	12	106	28	248
25	1"	50/25	2 1/4"	12	106	12	106	12	106	12	106	28	248
40	1 1/2"	-	-	20	177	25	221	30	266	45	398	80	708
50	2"	80/50 + 100/50	3 1/2" + 4 1/2"	25	221	30	266	35	310	50	443	120	1062
80	3"	-	-	60	531	100	885	160	1416	220	1947	250	2215
100	4"	150/100	6 3/4"	80	708	130	1151	200	1770	280	2478	350	3098
150	6"	-	-	350	3098	450	3983	600	5310	-	-	1200	10620
200/150	8 7/8"	-	-	350	3098	450	3983	600	5310	-	-	1200	10620

## k<sub>v100</sub>/Cv-values\*

KN, KNA, KA-N*	
k <sub>v100</sub>	Cv
m <sup>3</sup> /h	USgpm
17,5	20
31	36
75	87
200	233
310	361
800	932
1250	1456
2800	3262
3200	3728

\* for KNR and KNAR k<sub>v100</sub>/Cv-values see separate brochure

# KN, KNA, KNR, KA-N, KK

## Dimensions, weights

**KN, KNR (ISO/DIN):** Installation dimensions and approx. weights  
Face-to-face ISO 5752 series 1 (DIN 3202 F1), flanges ISO 7005-2\*\*

DN		Ø Port		L		HL		H		D		k		nxd <sub>1</sub>		EN ISO 5211	H <sub>1</sub>		H <sub>5</sub>		H <sub>2</sub>		Weight man. act.	
mm	inch	mm	inch	mm	inch	mm	inch	mm	inch	mm	inch	mm	inch	mm	inch		mm	inch	mm	inch	mm	inch	kg	lbs
15	½"	15	0,59	130	5,12	179	7,0	130	5,12	95	3,74	65	2,56	4x14	4x0,55	F05	50	1,97	60	2,36	60	2,36	5,6	12,3
20	¾"	20	0,79	150	5,91	179	7,0	130	5,12	105	4,13	75	2,95	4x14	4x0,55	F05	50	1,97	60	2,36	60	2,36	6	13,2
25	1"	24,5	0,96	160	6,30	179	7,0	130	5,12	115	4,53	85	3,35	4x14	4x0,55	F05	50	1,97	60	2,36	60	2,36	6	13,2
40	1½"	38	1,50	200	7,87	259	10,2	155	6,10	150	5,91	110	4,33	4x19	4x0,75	F07	77	3,03	94	3,70	60	2,36	14	30,9
50	2"	47,5	1,87	230	9,06	259	10,2	155	6,10	165	6,5	125	4,92	4x19	4x0,75	F07	80	3,15	97	3,82	60	2,36	16	35,3
80	3"	78	3,07	310	12,2	410	16,1	180	7,09	200	7,87	160	6,30	8x19	8x0,75	F10	118	4,65	140	5,51	80	3,15	35	77
100	4"	96	3,78	350	13,8	410	16,1	195	7,68	220	8,66	180	7,09	8x19	8x0,75	F10	134	5,28	156	6,14	80	3,15	55	121
150	6"	145	5,71	480	18,9	513*	20,2*	265	10,4	285	11,2	240	9,45	8x23	8x0,91	F12	184	7,24	215	8,46	100	3,94	104	229
200/150	8"/6"	145	5,71	457	18	513*	20,2*	265	10,4	340	13,4	295	11,61	8x23	8x0,91	F12	184	7,24	215	8,46	100	3,94	125	276
200	8"	195	7,68	457	18	No lever, only gear				343	13,5	295	11,61	12x23	8x <sup>7</sup> / <sub>8</sub>	F12	237	9,33	267,5	10,53	100	3,94	170	375

\* DN 150 (6) and 200 (8): At Δp > approx. 2 bar (29 psi) a worm gear is recommended instead of the hand lever. Details on request.

\*\* On request: drilled to ANSI B16.5 Cl.150

**KNA, KNAR (ASME):** Installation dimensions and approx. weights

Face-to-face ASME B16.10 short, flanges ASME B16.5 Cl.150\*\*

DN		Ø Port		L		HL		H		D		k		nxd <sub>1</sub>		EN ISO 5211	H <sub>1</sub>		H <sub>5</sub>		H <sub>2</sub>		Weight man. act.	
mm	inch	mm	inch	mm	inch	mm	inch	mm	inch	mm	inch	mm	inch	mm	inch		mm	inch	mm	inch	mm	inch	kg	lbs
15***	½"***	15	0,59	130	5,12	179	7,0	130	5,12	89	3,5	60,5	2,38	4x16	4x <sup>3</sup> / <sub>8</sub>	F05	50	1,97	60	2,36	60	2,36	5,6	12,3
20***	¾"***	20	0,79	150	5,91	179	7,0	130	5,12	98,5	3,88	70	2,76	4x16	4x <sup>3</sup> / <sub>8</sub>	F05	50	1,97	60	2,36	60	2,36	6	13,2
25	1"	24,5	0,96	127	5,0	179	7,0	130	5,12	108	4,25	79,5	3,13	4x16	4x <sup>3</sup> / <sub>8</sub>	F05	50	1,97	60	2,36	60	2,36	5,6	12,3
40	1½"	38	1,50	165	6,5	259	10,2	155	6,10	127	5,0	98,5	3,88	4x16	4x <sup>3</sup> / <sub>8</sub>	F07	77	3,03	94	3,70	60	2,36	12	26,4
50	2"	47,5	1,87	178	7,0	259	10,2	155	6,10	152,5	6,0	120,5	4,75	4x19	4x <sup>3</sup> / <sub>8</sub>	F07	80	3,15	97	3,82	60	2,36	14,5	32
80	3"	78	3,07	203	8,0	410	16,1	180	7,09	190,5	7,5	152,5	6,0	4x19	4x <sup>3</sup> / <sub>8</sub>	F10	118	4,65	140	5,51	80	3,15	33,5	74
100	4"	96	3,78	229	9,0	410	16,1	195	7,68	229	9,02	190,5	7,5	8x19	8x <sup>3</sup> / <sub>8</sub>	F10	134	5,28	156	6,14	80	3,15	50	110
150	6"	145	5,71	267	10,5	513*	20,2*	265	10,4	279,5	11,0	241,5	9,51	8x23	8x <sup>7</sup> / <sub>8</sub>	F12	184	7,24	215	8,46	100	3,94	91	201
200/150	8"/6"	145	5,71	457	18	513*	20,2*	265	10,4	343	13,5	298,5	11,75	8x23	8x <sup>7</sup> / <sub>8</sub>	F12	184	7,24	215	8,46	100	3,94	125	276
200	8"	195	7,68	457	18	kein Hebel sondern Getriebe				343	13,5	298,5	11,75	8x23	8x <sup>7</sup> / <sub>8</sub>	F12	237	9,33	267,5	10,53	100	3,94	170	375

\* DN 150 (6) and 200 (8): At Δp > approx. 2 bar (29 psi) a worm gear is recommended instead of the hand lever. Details on request.

\*\* On request: drilled to ISO 7005-2

\*\*\* face-to-face not to ANSI

**KA-N:** Installation dimensions and approx. weights

Special face-to-face, flanges ISO 7005-2 (optionally drilled to ASME B16.5 Cl.150)

DN/DN1		Ø Port		L		HL		H		D		k		nxd		D <sub>1</sub>		k <sub>1</sub>		nxd <sub>1</sub>		EN ISO 5211	H <sub>1</sub>		H <sub>5</sub>		H <sub>2</sub>		Weight man. act.	
mm	inch	mm	inch	mm	inch	mm	inch	mm	inch	mm	inch	mm	inch	mm	inch	mm	inch	mm	inch	mm	inch		mm	inch	mm	inch	mm	inch	kg	lbs
50/25	2"/1"	24,5	0,96	160	6,3	179	7,0	130	5,12	165	6,5	125	4,92	4x19	4x0,75	115	4,53	85	3,35	4x14	4x0,55	F05	50	1,97	60	2,36	60	2,36	8	17,6
80/50	3"/2"	47,5	1,87	210	8,27	259	10,2	155	6,1	200	7,87	160	6,3	8x19	8x0,75	165	6,5	125	4,92	4x19	4x0,75	F07	80	3,15	97	3,82	60	2,36	17	37
100/50	4"/2"	47,5	1,87	210	8,27	259	10,2	155	6,1	220	8,66	180	7,09	8x19	8x0,75	165	6,5	125	4,92	4x19	4x0,75	F07	80	3,15	97	3,82	60	2,36	18	40
150/100	6"/4"	96	3,78	325	12,8	410	16,1	195	7,68	285	11,2	240	9,45	8x23	8x0,91	229	9,02	180	7,09	8x19	8x0,75	F10	134	5,28	156	6,14	80	3,15	51,5	114

**KK:** Installation dimensions and approx. weights

Special face-to-face "DN + 50 mm", flangeless sandwich design

DN		Ø Port		L		HL		H		EN ISO 5211	H <sub>1</sub>		H <sub>5</sub>		H <sub>2</sub>		Weight man. act.	
mm	inch	mm	inch	mm	inch	mm	inch	mm	inch		mm	inch	mm	inch	mm	inch	kg	lbs
25	1"	24	0,94	75	2,95	143	5,6	120	4,72	F05	44	1,73	70,5	2,78	60	2,36	1,7	3,7
40	1½"	38	1,50	90	3,54	225	8,9	165	6,5	F07	69	2,72	105	4,13	60	2,36	3,7	8,2
50	2"	46	1,81	100	3,94	225	8,9	170	6,69	F07	73	2,87	109	4,29	60	2,36	4,3	9,5
65	2½"	46	2,28	115	4,53	225	8,9	170	6,69	F07	73	2,87	109	4,29	60	2,36	6	13,2
80	3"	65	3,07	130	5,12	225	8,9	190	7,48	F07	105	4,13	141,5	5,57	60	2,36	8	17,6
100	4"	78	3,07	150	5,91	325	12,8	190	7,48	F10	113	4,45	160	6,3	80	3,15	13,5	30
150	6"	110	4,33	200	7,87	385	15,2	240	9,45	F12	159	6,26	207	8,15	100	3,94	32,5	72

# YOUR SAFETY IS OUR GOAL. WORLDWIDE.

Distributed by:



Richter Chemie-Technik GmbH  
Otto-Schott-Str. 2  
D-47906 Kempen / Germany

Phone +49 (0) 2152 / 146-0  
Fax +49 (0) 2152 / 146-190



Richter (EP), Nanjing, Shanghai Office  
Room 3502 - 3504, Zhaofeng Plaza  
No. 1027, Changning Road,  
Shanghai 200050 / China

Phone +86 / 21 / 5241 - 5599  
Fax +86 / 21 / 5241 - 2870



Richter Pumps and Valves Inc.  
A Unit of IDEX Corporation  
406 State Street  
Cedar Falls, IA 50613 / USA

Phone +1 / 319 / 268-8038  
Fax +1 / 803 / 216-7702



Richter Pumps & Valves India  
R.S. No.: 256, Manjusar GIDC  
Nr. Bombardier Circle, Savli,  
Vadodara 391770 / India

Phone +91 / 2667 / 662 - 001  
Fax +91 / 2667 / 662 - 002



[richter-ct.com](http://richter-ct.com)  
[rkg-cs-inbox@idexcorp.com](mailto:rkg-cs-inbox@idexcorp.com)



Scan for more  
info on Richter

