

- Schuifafsluiter met vastgebout deksel
- Volle doorlaat
- Outside stem & yoke
- Class 800 lbs
- Laseinden socket weld volgens ANSI B16.11
- Met trim 5
- Materialen volgens: ISO 15156  
NACE MR.0175 ED. 2009  
NACE MR.0103 ED. 2012

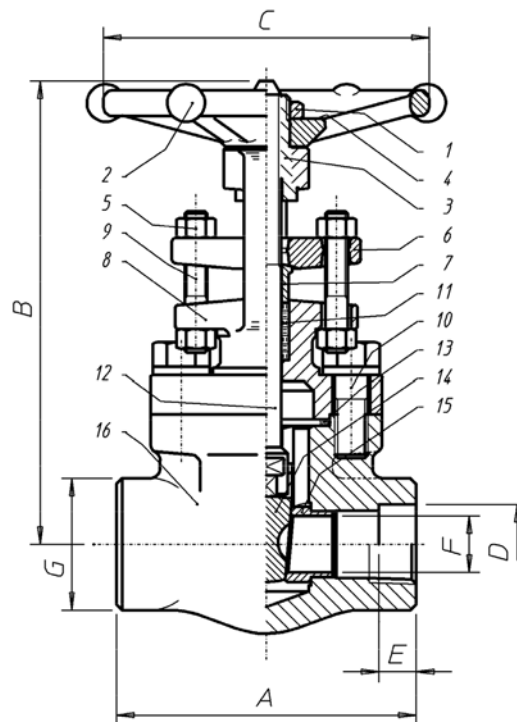



**MATERIALEN:**

N°	Omschrijving	Materialen
1	Handwiel moer	A563 GR.A BZP
2	Handwiel	ASTM A 105
3	Huls brugstuk	AISI 416
4	Naamplaatje	Aluminium
5	Moer pakkingdrukker	ASTM A194 2HM
6	Flens pakkingdrukker	ASTM A105
7	Pakkingdrukker	UNS S31603
8	Deksel	ASTM A105N
9	Draadstangen pakkingdrukker	ASTM A193 B7M
10	Bouten	ASTM A193 B7M
11	Pakking	Grafoil 3G/SP
12	Spindel	ASTM A479 410
13	Pakking	F316L + grafiet
14	Schuif	A182 F6A/ST.6
15	Zittingen	A479 410/ST.6
16	Huis	ASTM A105N

**AFMETINGEN: (mm)**

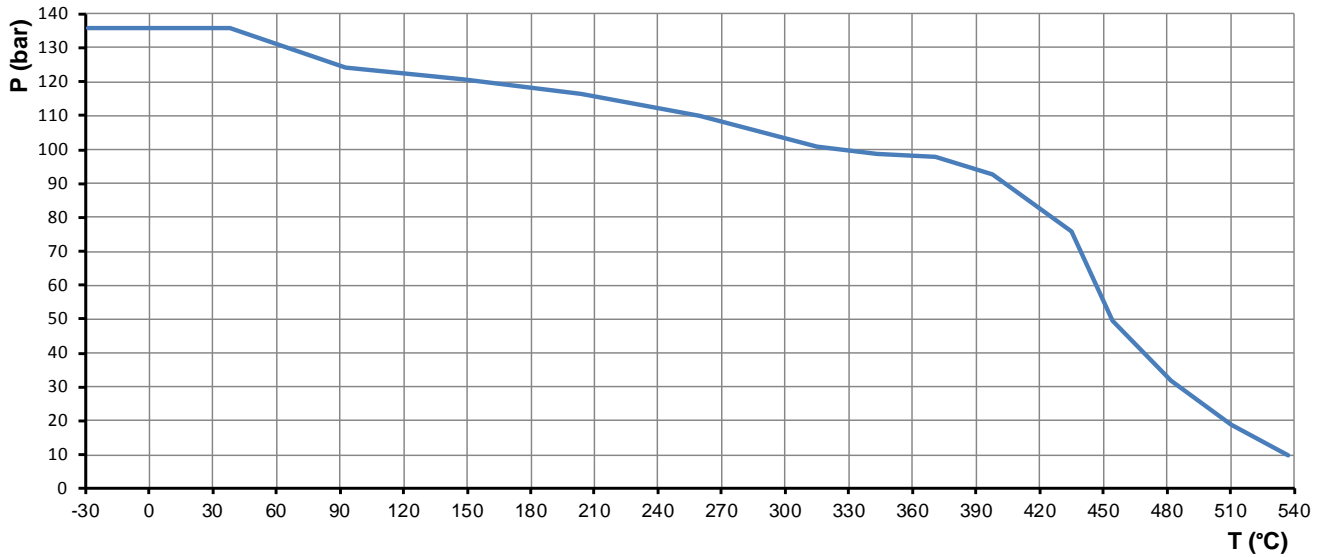
Ø	A	B	C	D	E	F	G	Kg
1/2"	90	158	88	21,7	12,7	14	38	2,3
3/4"	110	196	97	27,1	14,3	18	48	3,7
1"	127	225	138	33,8	15,8	24	56	5,9
1 1/2"	134	270	138	48,6	19	36,6	78	7,5
2"	152	330	172	61,1	22,2	46,5	78	12,5

**PT DIAGRAMMA:**

**KV-WAARDES: (m<sup>3</sup>/h)**

Ø	Kv
1/2"	10,4
3/4"	19,9
1"	37,2
1 1/2"	84,8
2"	170,4