

- Schuifafsluiter met vastgebout deksel
- Gereduceerde doorlaat
- Outside stem & yoke
- Class 800 lbs
- NPT schroefdraad volgens ANSI B1.20.1
- Beschikbaar in trim 5 (BFE-S21A5) of trim 8 (BFE-S21A8)
- Materialen volgens: ISO 15156
NACE MR.0175 ED. 2009
NACE MR.0103 ED. 2012

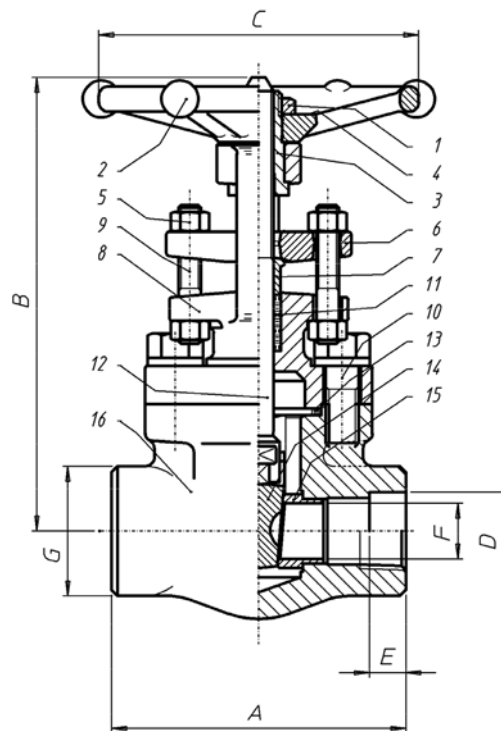



MATERIALEN:

N°	Omschrijving	Materialen	
		BFE-S21A5	BFE-S21A8
1	Handwiel moer	ASTM A307 GR.A BZP	
2	Handwiel	ASTM A 105	
3	Huls brugstuk	AISI 416	
4	Naamplaatje	Aluminium	
5	Moer pakkingdrukker	ASTM A194 2HM	
6	Flens pakkingdrukker	ASTM A105	
7	Pakkingdrukker	UNS S31603	
8	Deksel	ASTM A105N	
9	Draadstangen pakkingdrukker	ASTM A193 B7M	
10	Dekselmoer	ASTM A193 B7M	
11	Pakking	Grafoil 3G/SP	
12	Spindel	ASTM A479 410	
13	Pakking	F316L + grafiet, spiraalgewonden	
14	Schuif	A182 F6A/ST.6	ASTM A182 F6A NACE
15	Zitting	A479 410/ST.6	
16	Huis	ASTM A105N	

AFMETINGEN: (mm)

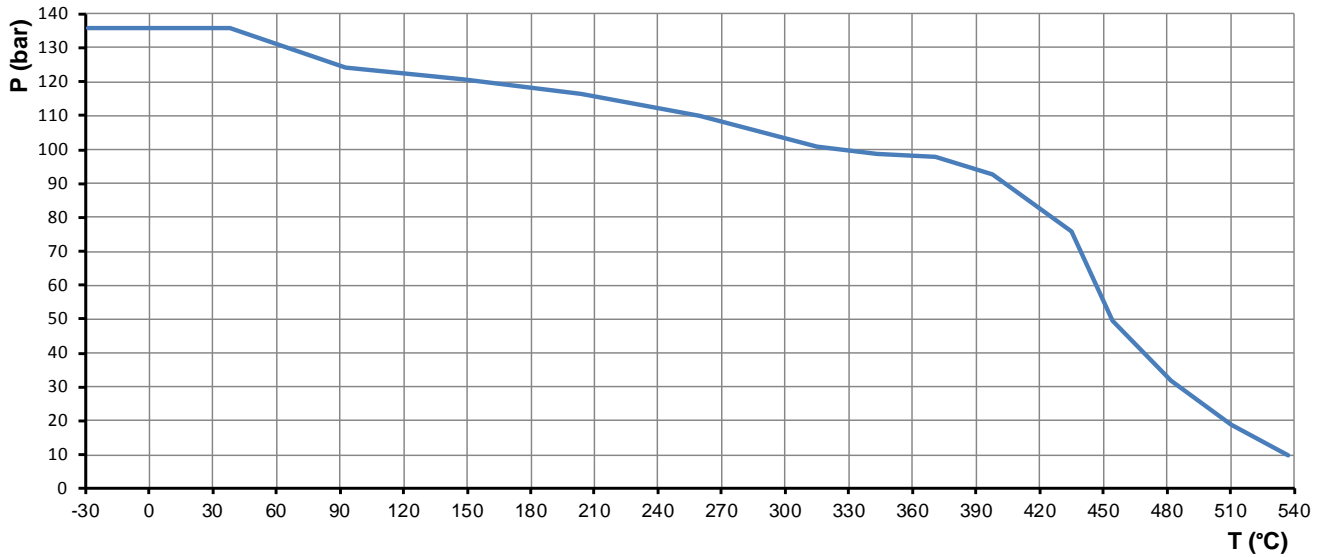
Ø	A	B	C	D	E	F	G	Kg
1/2"	80	152	88	21,7	12,7	9,6	32	1,9
3/4"	90	158	88	21,7	14,3	14	38	2,3
1"	110	196	97	33,6	15,8	18	48	3,6
1 1/2"	127	255	138	48,6	19	30	64	7,3
2"	134	270	138	61,1	22,2	36,6	78	7,5

PT DIAGRAMMA:

KV-WAARDES: (m³/h)

Ø	Kv
1/2"	4,8
3/4"	9,5
1"	22,1
1 1/2"	66,6
2"	83,9