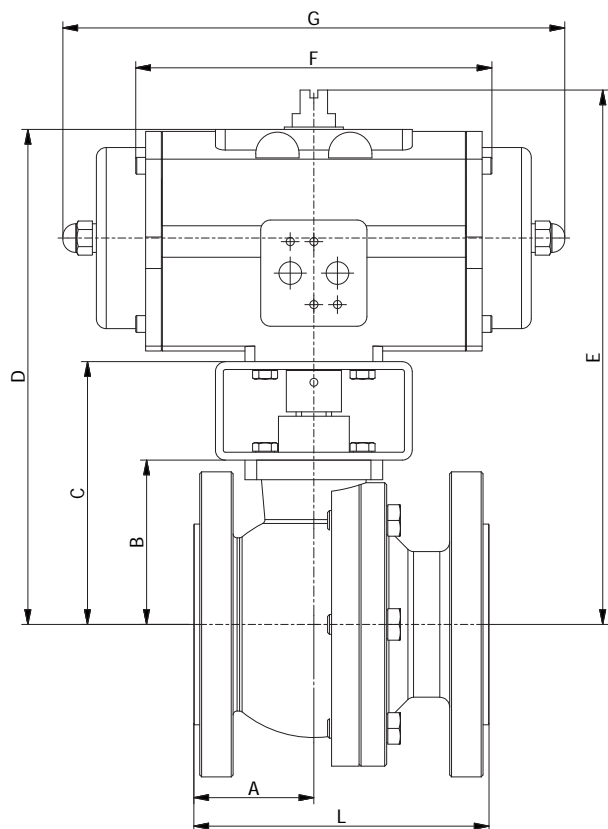

FIGUUR:
PD: Pneumatische bediening, dubbelwerkend

PE: Pneumatische bediening, enkelwerkend

AFMETINGEN: (mm)

DN	L	A	B	PD						PE					
				PD	C	D	E	F	Kg	PE	C	D	E	G	Kg
65	170	76	97	100	157	288	308	247	20,8	200	157	320	340	362	27,0
80	180	75	111	200	171	334	354	256	29,8	350	171	372	392	385	40,9
100	190	91	133	200	213	376	396	256	42,2	600	213	461	491	476	64,0
125	325	120	156	350	236	437	457	269	69,4	950	236	504	534	658	98,6
150	350	135	183	600	263	511	541	336	104,9	1600	283	585	615	732	154,3

De pneumatische bediening is berekend voor een stuurdruk van 6 bar, met een veiligheidsfactor van 30% en een maximale verschildruk van 40 bar. Voor standaard bedrijfsomstandigheden.

TOEBEHOREN:

Magneetventielen, eindloopschakelaars, noodhandbediening, pneumatische of elektro-pneumatische klepstandsteller.

ALGEMENE KENMERKEN:

- Tweedelig huis - vlottende kogel - volle doorlaat - niet-uitdrukbare spindel
- Anti-static device volgens BS 5351, ISO 7121 en NF E29-470
- Drukvereffeningsboring (standaard= 5 mm) in de bovenzijde van de kogel voorkomt overdruk in de ruimte tussen de kogel en het huis
- Alle afsluiters voldoen aan de TA Lüft-vereisten
- Fire Safe
- Max. temperaturen: -29°C ~ 230°C (AIT) en -50°C ~ 230°C (IIT)



Fire safe tested



ONTWERP	
Kogelkraan	EN 1983
Huis	EN 12516
Laagdikte	EN ISO 17292
Flenzen	DIN 2501, EN 1092-1
Inbouwlengte	EN 558-1 Series 27
Opbouwflens	ISO 5211
Afwerking bescherm laag	MSS SP 55
Markering	EN 19, CE-PED
TESTEN EN CERTIFICATEN	
Kwaliteit	ISO 9001, CE-PED
Fire Safe certificaten	ISO 10497, API 607, API 6FA
Druktest	EN 12266
Fugitive emissions	ISO 15848
TA Luft	VDI 2440
SIL	Level 3 IEC 61508
Andere	ISO 14001, ATEX, EN13774

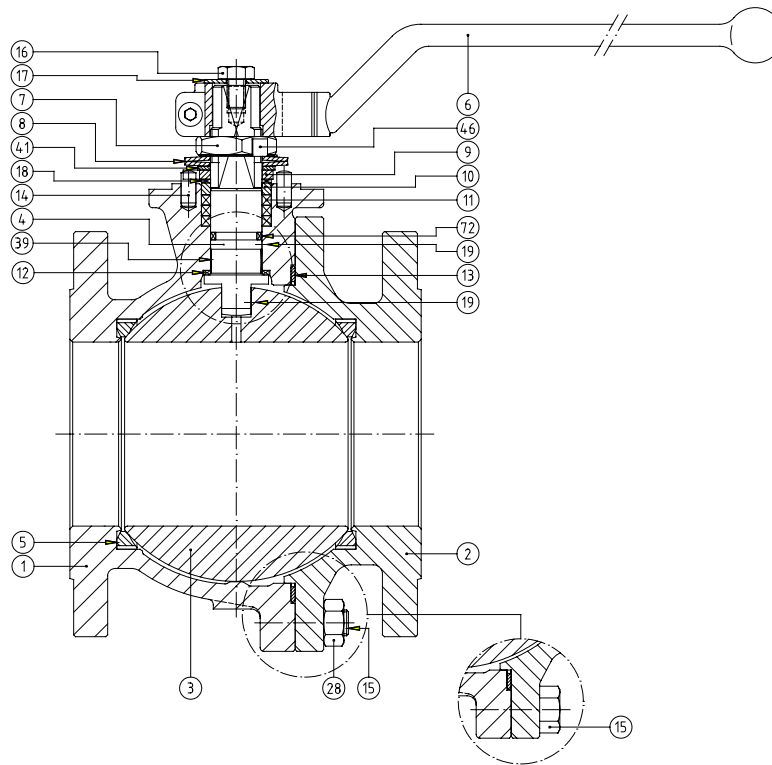

Pos.	Omschrijving	Materialen	
		AIT	IIT
1	Huis	1.0619	1.4408
2	Aansluitflens	1.0619	1.4408
3	Kogel	A 351 Gr. CF8M (DN 15 : 25 A 479 Tp.316)	
4	Spindel	F51	
5	Zitting	PTFE	
6	Hendel	A 216 Gr. WCB	
7	Spindelmoer	Staal, verzinkt	AISI 303
8	Schotelveer	Staal	Roestvast staal A666 TP.301
9	Stopplaat	Staal	AISI 304
10	Pakkingdrukker	AISI 303	AISI 316
11	Pakking	Grafiet	
12	Glijring	25% G.F. PTFE	
13	Huisafdichting	AISI 316L + PTFE + grafiet	
14	Stop	Staal	Roestvast staal
15	Bout (DN 32 t/m DN 100 tapeinden)	DIN 933 Gr.8.8	DIN 933 A4-70
16	Bout	DIN 933 A4-70	
17	Rondel	Staal, verzinkt	AISI 304
18	Rondel	25% G.F. PTFE	
19	Antistatic device	Roestvast staal	
28	Moer (DN 32 t/m DN 100)	DIN 934 Gr.8	DIN 934 A4-70
39	Spindelgeleiding (DN 25 t/m DN 200)	25% G.F. PTFE	
41	Rondel (DN 40 t/m DN 200)	Staal	AISI 304
46	Rondel	AISI 304	
72	O-ring	FKM	
	Identificatieplaatje	Roestvast staal	

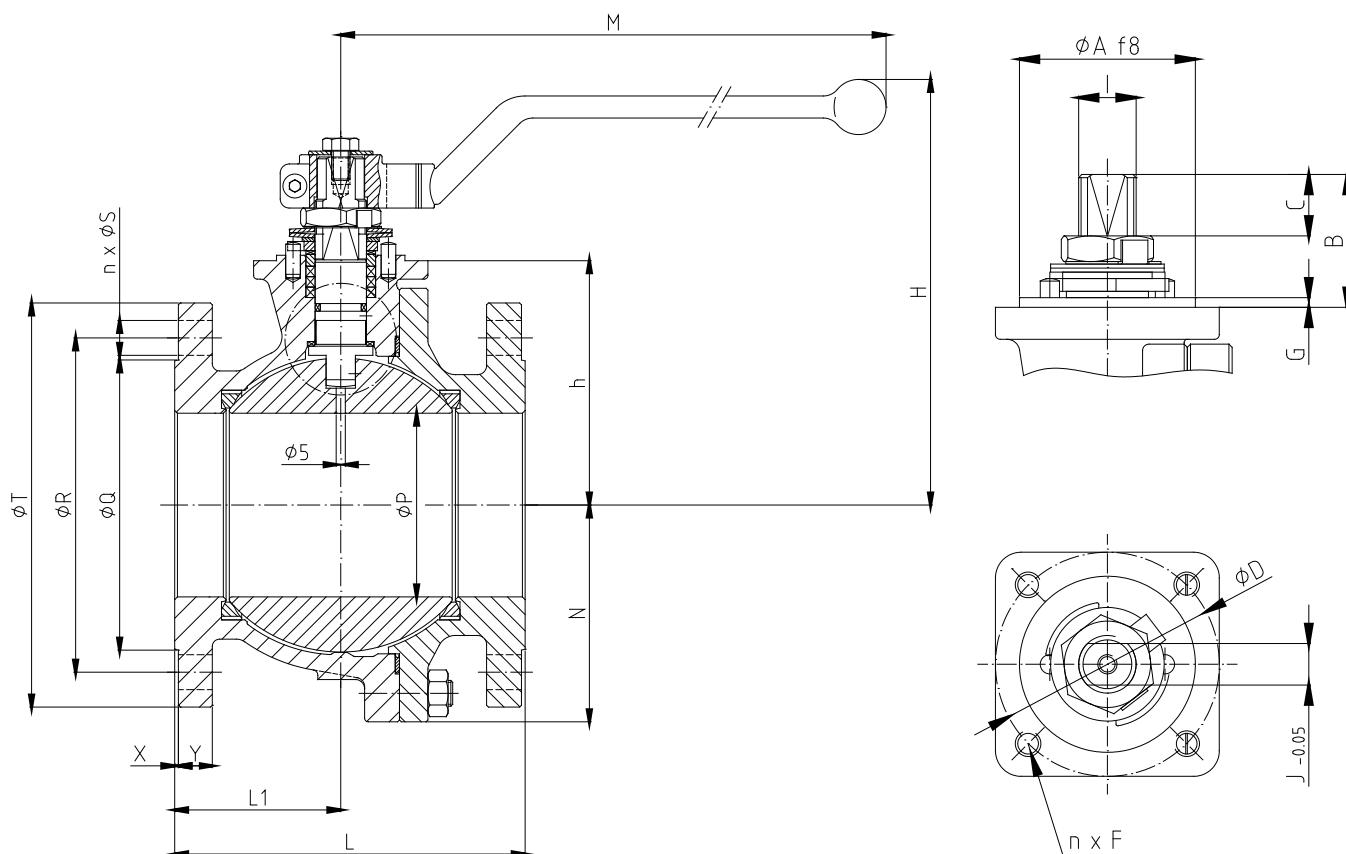
AFMETINGEN: (in mm)

DN	Ø P	L	L1	Ø Q	Ø R	n x Ø S	Ø T	X	Y	h	N	H	M	Kg
65	65	170	75,5	122	145	8x18	185	3	19	97	-	169	348	17,0
80	80	180	74,5	138	160	8x18	200	3	21	111	-	207	445	23,0
100	100	190	91	162	190	8x22	235	3	21	133	118,0	232	495	35,0
125	125	325	120	188	220	8x26	270	3	23	156	138,0	265	698	57,0
150	151	350	135	218	250	8x26	300	3	25	183	160,0	298	698	83,5

OPBOUWFLENS: (in mm)

DN	ISO	Ø A	B	C	Ø D	n x F	G	I	J
65	F07	55	44,0	18,6	70	4x M8	3,0	M22x1.5	16
80	F10	70	44,5	18,6	102	4x M10	3,0	M25x1.5	18
100	F10	70	56,5	27,8	102	4x M10	3,0	M28x1.5	20
125	F12	85	56,0	24,8	125	4x M12	3,0	M35x2	25
150	F12	85	68,0	37,1	125	4x M12	3,0	M40x2	29

DRUK-TEMPERATUURDIAGRAMMA:

AIT

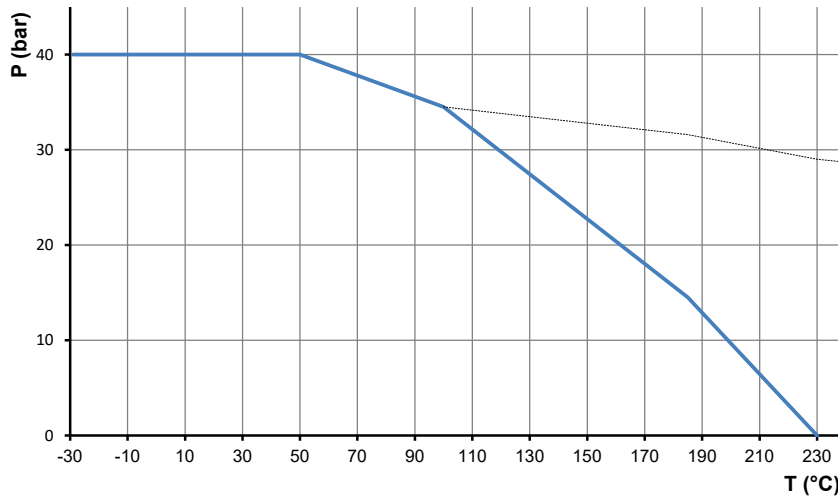

IIT

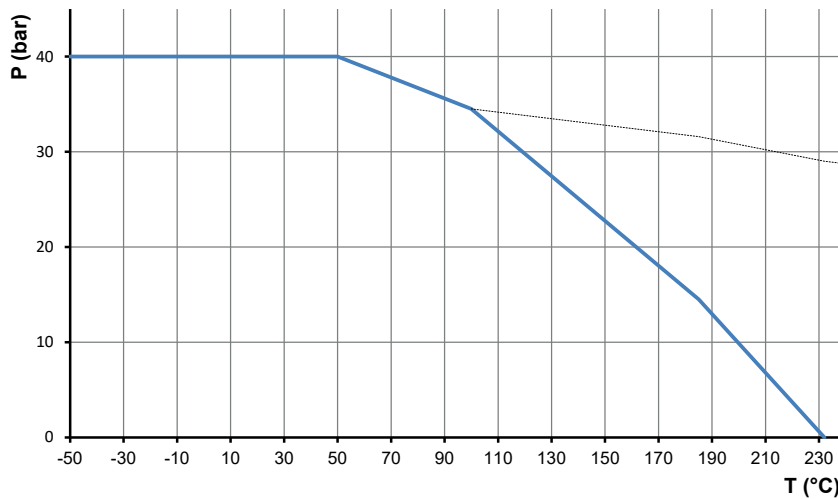

DRAAIMOMENT: (in Nm)

DN	Verschildruk
	40 bar
65	66
80	116
100	171
125	283
150	463

Kv-WAARDE: (in m³/h)

DN	Kv-waarde
65	550
80	1.000
100	1.650
125	3.000
150	4.200

ALGEMENE KENMERKEN:

- Rack & pinion pneumaat
- Slagregeling:
 - 0°~90° -5°/+10° en +80° ~ +95° (grootte 25 ~ grootte 600)
 - 0°~90° -3°/+10° en +80° ~ +93° (grootte 950 ~ grootte 4000)

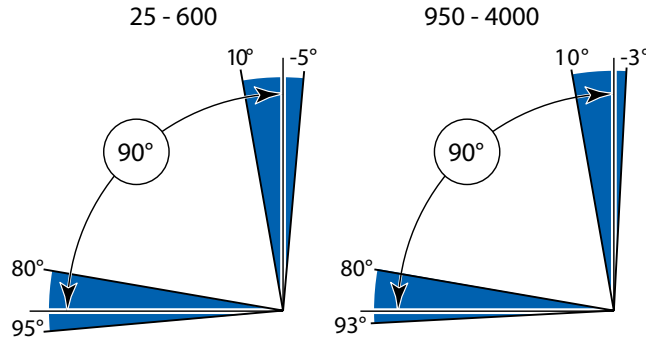

- Werktemperatuur:
 - Standaard: -20 °C ~ 80 °C
 - Lage temperatuur versie (Silicone): -40°C ~ 80°C
 - Hoge temperatuur versie (Viton): -10°C ~ 120°C
- Stuurdruk: 3 ~ 8 bar
- Koppeling volgens ISO 5211 en DIN 3337
- Opbouw van magneetventielen volgens Namur Std.
- Opbouw van naderingschakelaars volgens Namur
- Min. 500.000 cycli

FIGUUR:

- PD:** dubbelwerkend
- PE:** enkelwerkend, normaal gesloten
- PEO:** enkelwerkend, normaal open

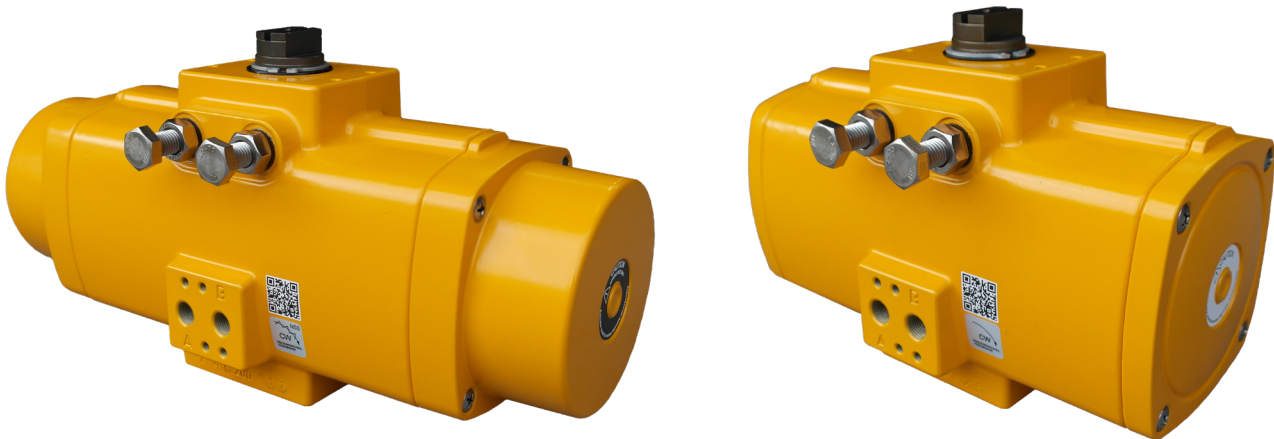

ONTWERP

Opbouw van magneetventielen	NAMUR Std.
Opbouw van toebehoren	NAMUR VDI, NAMUR VDE 3845 Std.
Aansluiting	ISO 5211, DIN 3337

TESTEN EN CERTIFICATEN

Veiligheid	ATEX II 2 GD, SIL3
Kwaliteit	CE/PED, ISO9001

PD 0012 / PE 0012

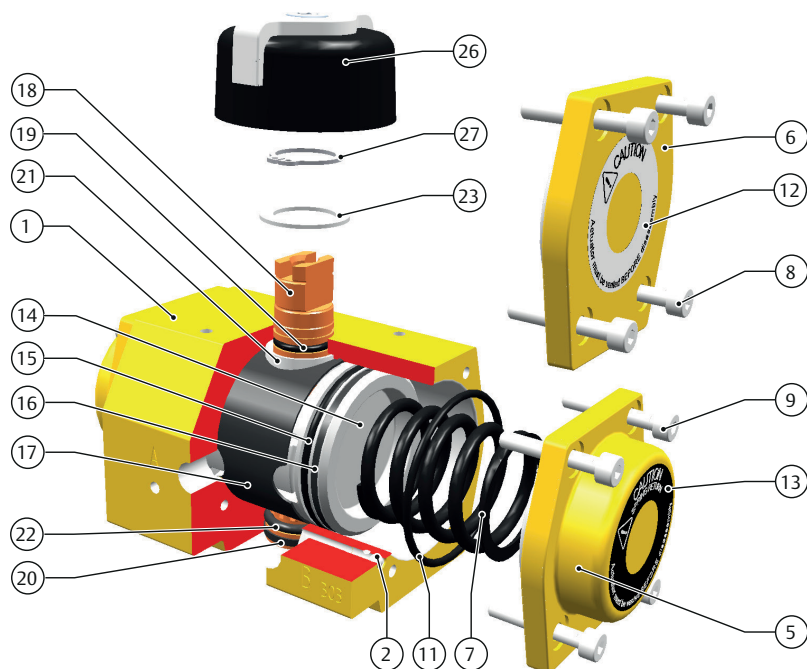
MATERIALEN:

Pos.	Omschrijving	Materiaal
1	Huis	Geëxtrudeerd aluminium (polyurethaan gecoat)
2 *	Kogel aansluiting B	Staal
5	Deksel enkelwerkend	Gegoten aluminiumlegering (polyurethaan gecoat)
6	Deksel dubbelwerkend	Gegoten aluminiumlegering (polyurethaan gecoat)
7	Verenpakket	Veerstaal (elektroforetisch gecoat)
8	Schroef deksel	Roestvast staal
9	Schroef deksel	Roestvast staal
11 *	O-ring deksel	Nitril rubber
12	Sticker dubbelwerkend	Polyester
13	Sticker enkelwerkend	Polyester
14	Zuiger	Gegoten aluminiumlegering (gechromatiseerd)
15 *	Lagering Zuiger	PTFE, 25% koolstof gevuld
16 *	O-ring zuiger	Nitril rubber
17 *	Geleidingsband	Nylatron
18	Kamwiel	Aluminium (hard geanodiseerd)
19 *	Bovenste lager kamwiel	POM
20 *	Onderste lager kamwiel	POM
21 *	Bovenste o-ring kamwiel	Nitril rubber
22 *	Onderste o-ring kamwiel	Nitril rubber
23 *	Druklager kamwiel	POM zwart (UV stabiel)
26	Standmelder	ABS + schroef in roestvast staal
27 *	Circlip	Veerstaal (Deltatone coating)

*inbegrepen in onderhoudskit

 Componenten lage temperaturen:
 - Castrol Optitemp TT1 vet
 -Silicone (MVQ70 rubber) O-ringen

 Componenten hoge temperaturen:
 - Castrol vet voor hoge temperaturen
 - Viton (FPM) O-ringen
 - Zuigerringen in PTFE 25% koolstof versterkt
 - lager zuigerinrichting en kamwiel in Nylon 66 + aramidevezel & PTFE

PD 0025 - 0600 / PE 0012 - 0600

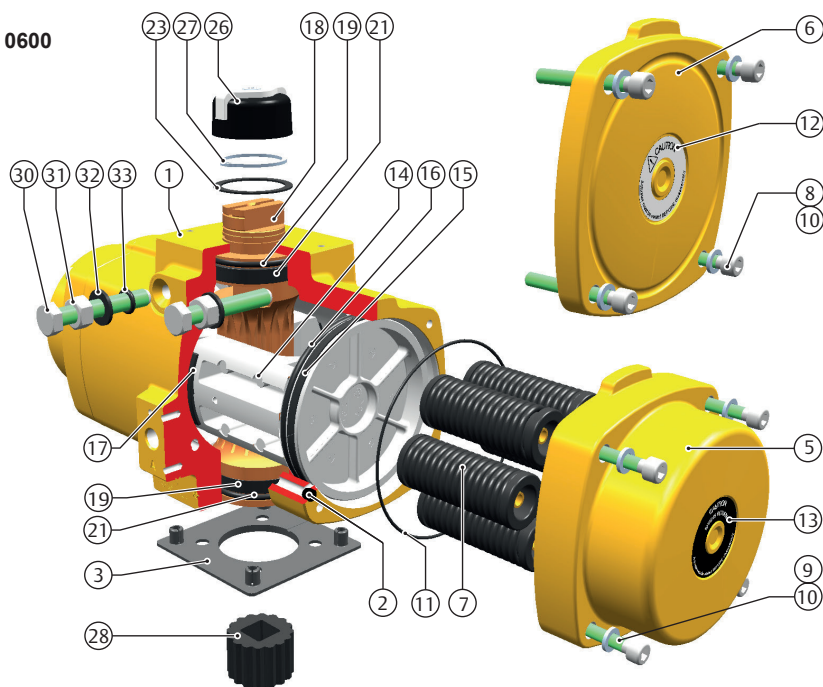
MATERIALEN:

Pos.	Omschrijving	Materiaal
1	Huis	Gegoten aluminiumlegering (polyurethaan gecoat)
2 *	Dichting aansluiting B	Silikonrubber
3	Centreerplaatje	Nylon PA6, zwart
5	Deksel enkelwerkend	Gegoten aluminiumlegering (polyurethaan gecoat)
6	Deksel dubbelwerkend (hoog deksel ook voor enkelwerkend tot en met type 0100)	Gegoten aluminiumlegering (polyurethaan gecoat)
7	Verenpakket	Veerstaal (elektroforetisch gecoat)
8	Schroef deksel	Roestvast staal
9	Schroef deksel	Roestvast staal
10	Sluitring schroef deksel	Roestvast staal
11 *	O-ring deksel	Nitril rubber
12	Sticker dubbelwerkend	Polyester
13	Sticker enkelwerkend	Polyester
14	Zuiger	Gegoten aluminiumlegering (gechromatiseerd)
15 *	Lagering Zuiger	PTFE, 25% koolstof gevuld
16 *	O-ring zuiger	Nitril rubber
17 *	Geleidingsband	POM
18	Kamwiel	Aluminium (hard geanodiseerd)
19 *	Lager kamwiel	POM
21 *	O-ring kamwiel	Nitril rubber
23 *	Druklager kamwiel	POM zwart (UV stabiel)
26	Standmelder	ABS + schroef in roestvast staal
27 *	Circlip	Veerstaal (Deltatone coating)
28	Insert	Aluminium (geanodiseerd)
30	Bout slagbegrenzing	Roestvast staal
31	Moer slagbegrenzing	Roestvast staal
32 *	Sluitring slagbegrenzing	PA66
33 *	O-ring slagbegrenzing	Nitril rubber

*inbegrepen in onderhoudskit

PD 0950 - 2500 / PE 0950 - 2500

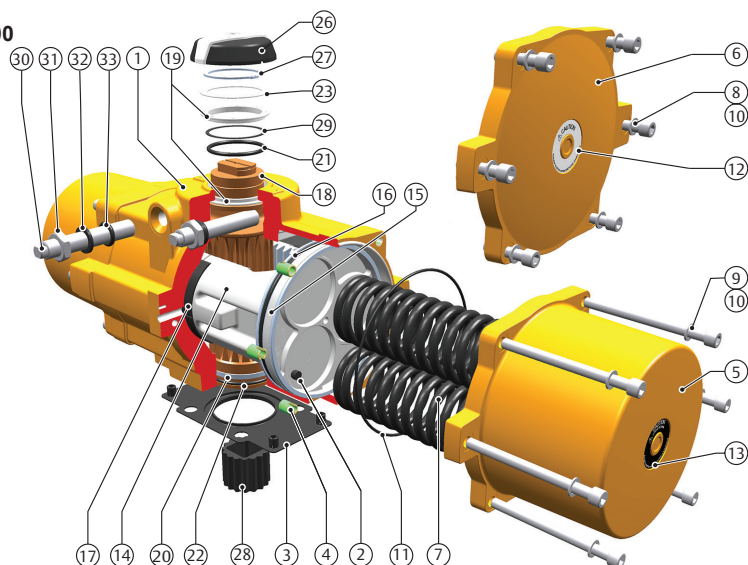
MATERIALEN:

Pos.	Omschrijving	Materiaal
1	Huis	Gegoten aluminiumlegering (polyurethaan gecoat)
2 *	Dichting aansluiting B	Silikonrubber
3	Centreerplaatje	Nylon PA6, zwart
4	Insert met schroefdraad	Staal
5	Deksel enkelwerkend	Gegoten aluminiumlegering (polyurethaan gecoat)
6	Deksel dubbelwerkend	Gegoten aluminiumlegering (polyurethaan gecoat)
7	Verenpakket	Veerstaal (elektroforetisch gecoat)
8	Schroef deksel	Roestvast staal
9	Schroef deksel	Roestvast staal
10	Sluiring schroef deksel	Roestvast staal
11 *	O-ring deksel	Nitril rubber
12	Sticker dubbelwerkend	Polyester
13	Sticker enkelwerkend	Polyester
14	Zuiger	Gegoten aluminiumlegering (gechromatiseerd)
15 *	Lagering Zuiger	PTFE, 25% koolstof gevuld
16 *	O-ring zuiger	Nitril rubber
17 *	Geleidingsband	POM
18	Kamwiel	Aluminium (hard geanodiseerd)
19 *	Bovenste lager kamwiel	POM
20 *	Onderste lager kamwiel	POM
21 *	Bovenste o-ring kamwiel	Nitril rubber
22 *	Onderste o-ring kamwiel	Nitril rubber
23 *	Drukager kamwiel	POM zwart (UV stabiel)
26	Standmelder	ABS + schroef in roestvast staal
27 *	Circlip	Veerstaal (Deltatone coating)
28	Insert	Aluminium (geanodiseerd)
29 *	Extra ring	POM
30	Bout slagbegrenzing	Roestvast staal
31	Moer slagbegrenzing	Roestvast staal
32 *	Sluiring slagbegrenzing	PA66
33 *	O-ring slagbegrenzing	Nitril rubber

*inbegrepen in onderhoudskit

PD 4000 / PE 4000

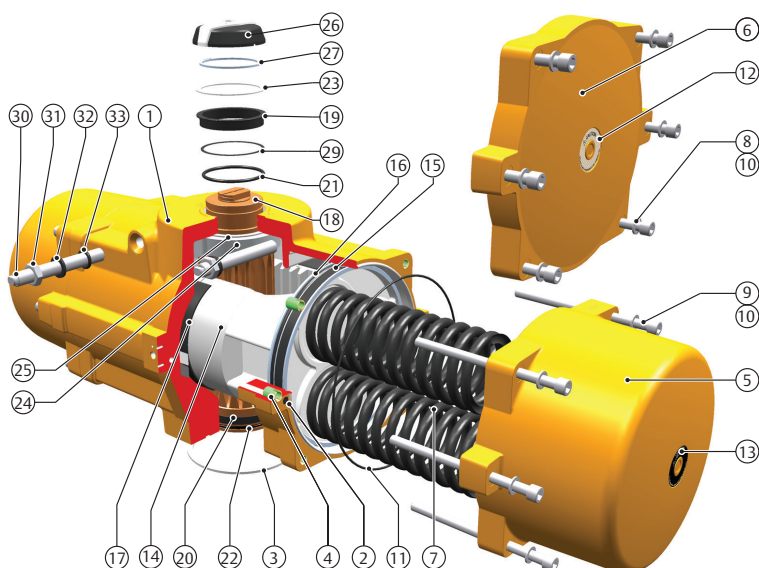
MATERIALEN:

Pos.	Omschrijving	Materiaal
1	Huis	Gegoten aluminiumlegering (polyurethaan gecoat)
2 *	Dichting aansluiting B	Silikonrubber
3	Centreerring	Roestvast staal AISI 304
4	Insert met schroefdraad	Staal
5	Deksel enkelwerkend	Gegoten aluminiumlegering (polyurethaan gecoat)
6	Deksel dubbelwerkend	Gegoten aluminiumlegering (polyurethaan gecoat)
7	Verenpakket	Veerstaal (elektroforetisch gecoat)
8	Schroef deksel	Roestvast staal
9	Schroef deksel	Roestvast staal
10	Sluitring schroef deksel	Roestvast staal
11 *	O-ring deksel	Nitril rubber
12	Sticker dubbelwerkend	Polyester
13	Sticker enkelwerkend	Polyester
14	Zuiger	Gegoten aluminiumlegering (gechromatiseerd)
15 *	Lagering Zuiger	PTFE, 25% koolstof gevuld
16 *	O-ring zuiger	Nitril rubber
17 *	Geleidingsband	POM
18	Kamwiel	Aluminium (hard geanodiseerd)
19 *	Bovenste lager kamwiel	POM
20 *	Onderste lager kamwiel	POM
21 *	Bovenste o-ring kamwiel	Nitril rubber
22 *	Onderste o-ring kamwiel	Nitril rubber
23 *	Druklager kamwiel	POM zwart (UV stabiel)
24	Afstelling slag nok	ABS + schroef in roestvast staal
25 *	Druklager nok	POM zwart (UV stabiel)
26	Standmelder	ABS + schroef in roestvast staal
27	Circlip	Veerstaal (Deltatone coating)
29 *	Extra ring	POM
30	Bout slagbegrenzing	Roestvast staal
31	Moer slagbegrenzing	Roestvast staal
32 *	Sluitring slagbegrenzing	PA66
33 *	O-ring slagbegrenzing	Nitril rubber

*inbegrepen in onderhoudskit

TYPE 12:

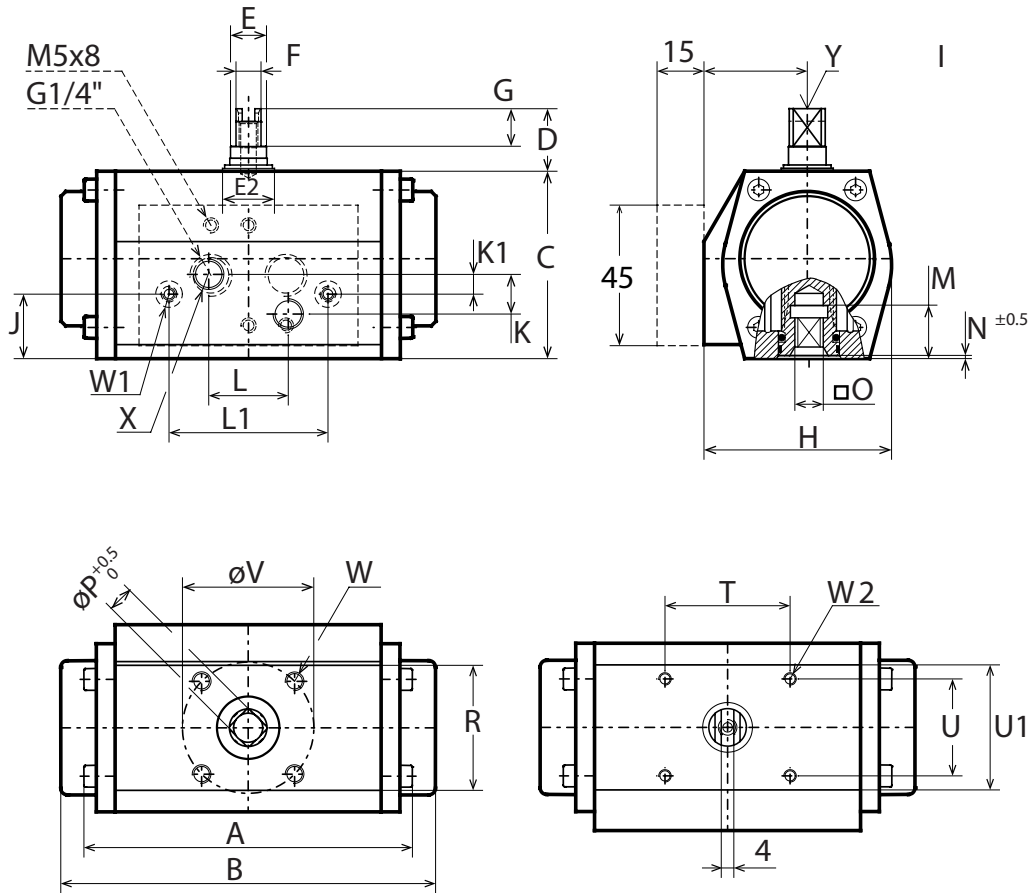

AFMETINGEN: (mm)

TYPE	A	B	C	D	E	F	G	H	I	J	K	K1	L	L1	M
0012	103	118	60	20	16	10	12	60	33,0	21	12,7	6,4	25,4	50,8	16,5

TYPE	N	O Max.	O Min.	P	T	U	V	W	W1	W2	X	Y	Kg (PD)	Kg (PE)
0012	1	9,14	9,05	12,1	40	31	42	M6x8	M4x7	M4x7	G 1/8"	M6x12	0,6	0,7

TYPE 25-350:

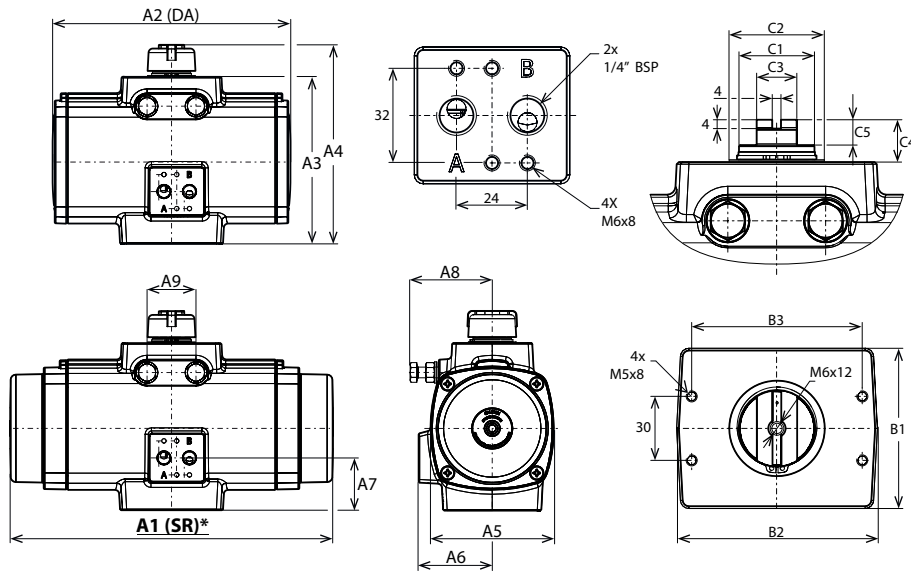

TYPE 600-4000:

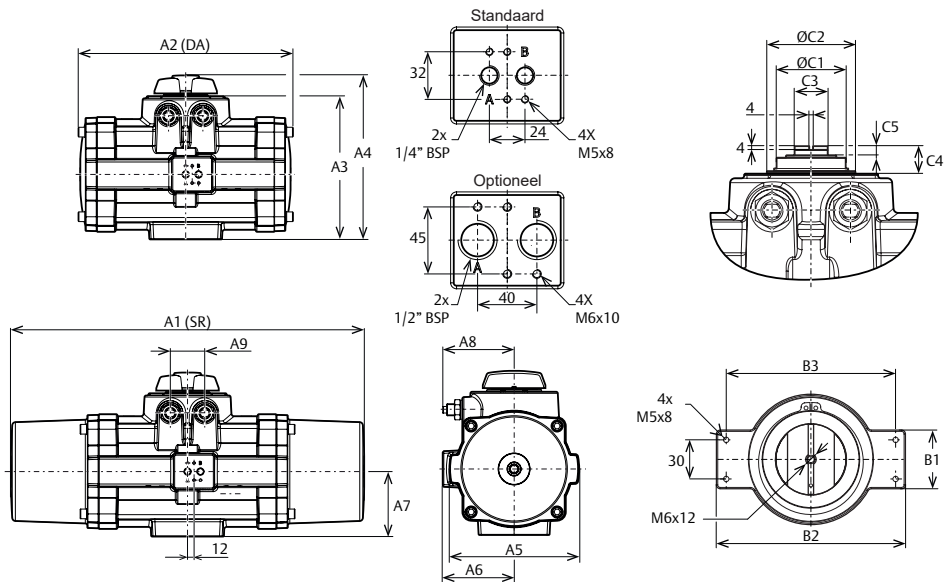

AFMETINGEN: (mm)

TYPE	A1*	A2*	A3	A4	A5	A6	A7	A8	A9	B1	B2	B3	C1	C2	C3	C4	C5	Kg (PD)	Kg (PE)
0025	166	166	91	119	82	49	30	48	18	43	94	80	16	23	10	20	12	1,4	1,6
0040	192	192	112	139	95	55	34	58	25	45	94	80	22	30	14	20	12	2,1	2,3
0065	217	217	124	151	104	58	38	69	27	50	94	80	22	30	14	20	12	2,8	3,3
0100	247	247	131	158	115	64	38	69	28	60	97	80	22	30	14	20	12	3,5	4,3
0150	304	223	157	185	127	69	49	75	46	75	94	80	34	45	14	20	12	4,9	6,6
0200	362	256	163	191	134	72	49	87	46	75	94	80	36	45	19	20	12	6	8,3
0350	385	269	201	230	165	85	42	109	46	85	100	80	36	45	19	20	12	10,2	14,5
0600	476	336	248	292	199	102	67	132	60	98	148	130	55	65	19	30	10	20	26
0950	658	400	268	305	239	131	121	131	64	45	145	130	65	83	36	30	10	36	41
1600	732	462	302	339	306	149	137 (140) **	156	85	45	145	130	75	96	36	30	10	41	62
2500	877	550	354	392	350	170	157 (160) **	181	102	45	145	130	95	118	36	30	10	64	100
4000	959	649	389	427	400	196	184 (186) **	175	184	45	145	130	96	115	36	30	10	103	147

* Tot en met type 0100 hebben enkelwerkende en dubbelwerkende pneumaten dezelfde deksels. Zie tekening met maat **A1 (SR)**

** Waarden tussen haakjes voor optionele 1/2" aansluiting

Wijzigingen voorbehouden

TYPE 25-4000:

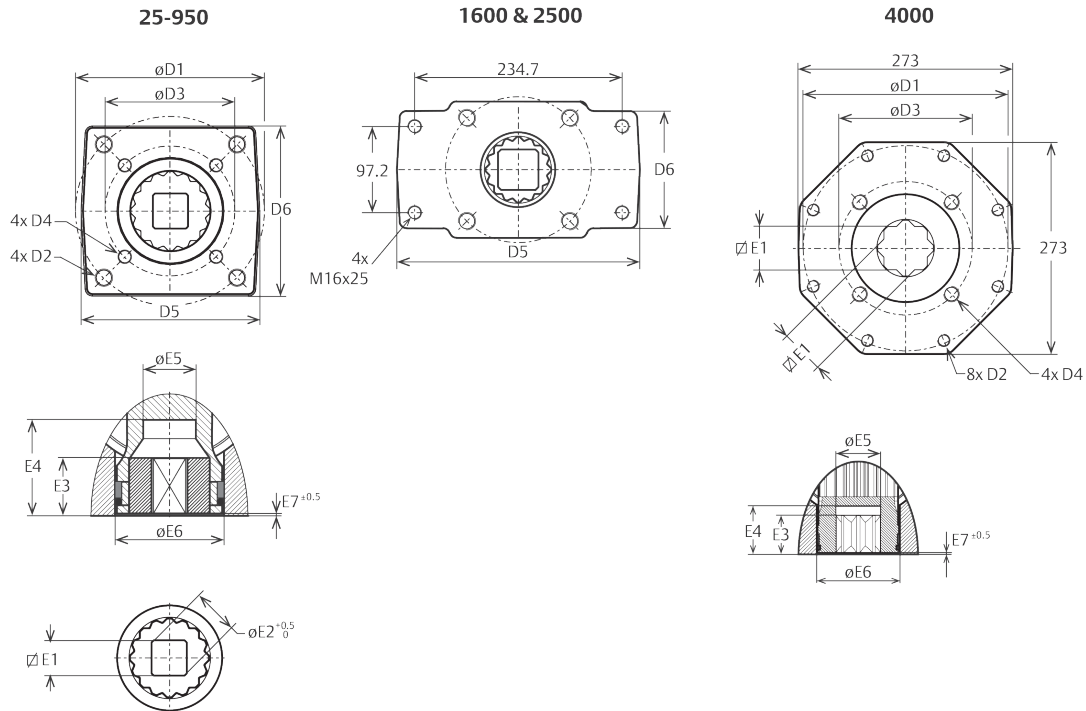

AFMETINGEN: (mm)

TYPE	ISO1	D1	D2	ISO2	D3	D4	D5	D6
0025	F05	50	M6x10	F03	36	M5x8	50	48
0040	F07	70	M8x13	F05	50	M6x10	68	65
0065	F07	70	M8x13	F05	50	M6x10	68	65
0100	F07	70	M8x13	F05	50	M6x10	66	63
0150	F10	102	M10x15	F07	70	M8x13	97	92
0200	F10	102	M10x15	F07	70	M8x13	94	90
0350	F10	102	M10x15	F07	70	M8x13	94	94
0600	F12	125	M12x18	F10	102	M10x16	118	113
0950	F14	140	M16x25	F10	102	M10x16	135	130
1600	F16	165	M20x20	F25 *	-	-	280	132
2500	F16	165	M20x20	F25 *	-	-	280	132
4000	F25	254	M16x25	F16	165	M20x20	273	269

TYPE	E1 Max.	E1 Min.	E2	E3	E4	E5	E6	E7
0025	11,08	11	14,1	15	34	14,1	24,5	0,5
0040	14,08	14	18,1	15	34	18,1	34,5	1
0065	14,08	14	18,1	15	34	21,1	34,5	1
0100	17,09	17	22,4	18	34	23,5	38	1
0150	17,08	17	22,4	27,5	50	28,5	56,5	1,2
0200	22,1	22	28,2	27,5	50	32,1	56,5	1,2
0350	22,1	22	28,2	27,5	50	32,1	56,5	1,2
0600	27,11	27	36,2	27,5	50	36,5	67,5	1,2
0950	36,16	36	58,2	48,5	65,5	48	86	1
1600	46,16	46	60,2	59,5	81,5	60	104	1
2500	46,16	46	60,2	59,5	81,5	60	125	1
4000	55,24	55	72,2	61,5	76,75	73	133	1

* Voor 1600 & 2500 zijn er slechts 4 boringen van een F25 aansluiting aanwezig

TYPE PD	Draaimoment voor dubbelwerkende pneumatische bediening in Nm																					
	2 bar		3 bar		3,5 bar		4 bar		4,5 bar		5 bar		5,5 bar		6 bar		6,5 bar		7 bar		8 bar	
	0°	90°	0°	90°	0°	90°	0°	90°	0°	90°	0°	90°	0°	90°	0°	90°	0°	90°	0°	90°	0°	90°
12	5		7		9		10		11		12		13		15		16		17		20	
25	9		13		16		18		20		23		25		27		29		32		36	
40	17		25		29		34		38		42		47		51		55		59		68	
65	25		38		45		51		58		64		71		77		84		90		104	
100	38		57		66		76		86		95		105		115		124		134		153	
150	60		91		106		122		137		153		168		183		199		214		245	
200	82		124		146		167		188		209		230		251		272		293		335	
350	143		216		253		290		326		363		400		436		473		510		583	
600	243		368		430		492		554		617		679		741		804		866		991	
950	368		557		651		746		840		935		1029		1124		1218		1312		1501	
1600	617		934		1092		1250		1408		1566		1725		1883		2041		2199		2516	
2500	956		1447		1692		1937		2182		2427		2673		2918		3163		3408		3899	
4000	1552		2348		2746		3144		3542		3940		4338		4736		5134		5532		6327	

TYPE PE	Verenpakket	Draaimoment voor enkelwerkende pneumatische bediening in Nm																		Veerslag	
		3 bar		3,5 bar		4 bar		4,5 bar		5 bar		5,5 bar		6 bar		7 bar		8 bar		EINDE	START
		0°	90°	0°	90°	0°	90°	0°	90°	0°	90°	0°	90°	0°	90°	0°	90°	0°	90°		
12	20	2	-	4	1	5	2	6	3	8	5	9	6	10	7	13	10	15	12	5	7
25	10	12	10	14	13	17	15	19	17	21	20	24	22	26	25	31	29	36	34	2	4
	20	9	6	12	9	14	11	16	13	19	16	21	18	24	21	28	25	33	30	4	7
	30	7	2	9	4	11	7	14	9	16	12	19	14	21	17	26	21	31	26	7	11
	40	-	-	-	-	9	3	11	5	14	8	16	12	19	14	21	17	26	21	9	14
	50	-	-	-	-	-	-	9	1	11	4	14	6	16	8	21	13	26	18	11	18
	60	-	-	-	-	-	-	-	-	-	-	-	11	2	13	4	18	9	23	14	13
40	10	22	19	26	24	31	28	36	33	40	37	45	42	49	46	58	55	67	64	4	7
	20	17	12	22	16	26	21	31	25	35	30	40	34	44	39	53	48	62	57	8	13
	30	12	4	17	9	21	13	26	18	31	22	35	27	40	31	49	40	58	49	12	20
	40	-	-	12	1	17	6	21	10	26	15	30	19	35	24	44	33	53	42	17	26
	50	-	-	-	-	-	-	17	3	21	7	26	12	30	16	39	25	48	34	21	33
	60	-	-	-	-	-	-	-	-	-	-	-	21	4	25	9	34	18	43	27	25
65	10	33	29	40	36	47	43	54	50	61	57	68	63	75	70	88	84	102	98	6	10
	20	26	17	33	24	40	31	47	38	53	45	60	52	67	59	81	72	95	86	13	20
	30	19	5	25	12	32	19	39	26	46	33	53	40	60	47	74	61	87	74	19	31
	40	-	-	-	-	25	8	32	14	39	21	46	28	52	35	66	49	80	63	26	41
	50	-	-	-	-	-	-	24	3	31	10	38	17	45	23	59	37	73	51	32	51
	60	-	-	-	-	-	-	-	-	-	-	-	31	5	38	12	52	25	65	39	39
100	10	49	43	60	53	70	64	80	74	90	84	100	94	111	104	131	125	151	145	9	15
	20	39	26	49	36	59	47	69	57	79	67	90	77	100	87	120	108	141	128	19	30
	30	28	9	38	19	48	30	59	40	69	50	79	60	89	70	109	91	130	111	28	44
	40	-	-	27	2	38	13	48	23	58	33	68	43	78	53	99	74	119	94	37	59
	50	-	-	-	-	-	-	37	6	47	16	57	26	68	36	88	57	108	77	47	74
	60	-	-	-	-	-	-	-	-	-	-	-	47	9	57	19	77	40	98	60	56
150	10	79	69	96	86	112	102	128	118	145	135	161	151	177	167	210	200	243	233	15	24
	20	62	42	79	59	95	75	111	91	128	108	144	124	160	140	193	173	226	206	30	47
	30	45	15	62	32	78	48	94	64	111	81	127	97	143	113	176	146	209	179	44	71
	40	-	-	45	5	61	21	77	37	94	54	110	70	126	86	159	119	192	152	59	94
	50	-	-	-	-	-	-	60	10	77	26	93	43	109	59	142	92	175	124	74	118
	60	-	-	-	-	-	-	-	-	-	-	-	76	16	92	32	125	65	158	97	89
200	10	108	94	131	117	153	139	175	161	198	184	220	206	242	228	287	273	332	318	21	33
	20	85	57	107	79	129	102	152	124	174	146	196	169	219	191	263	236	308	280	41	65
	30	61	19	83	42	106	64	128	86	150	109	173	131	195	153	240	198	284	243	62	98
	40	-	-	-	-	82	26	104	49	127	71	149	93	171	116	216	161	261	205	82	131
	50	-	-	-	-	-	-	81	11	103	34	125	56	148	78	192	123	237	168	103	163
	60	-	-	-	-	-	-	-	-	-	-	-	102	18	124	41	169	85	213	130	124

TYPE PE	Verenpakket	Draaimoment voor enkelwerkende pneumatische bediening in Nm																		Veerslag	
		3 bar		3,5 bar		4 bar		4,5 bar		5 bar		5,5 bar		6 bar		7 bar		8 bar		EINDE	START
		0°	90°	0°	90°	0°	90°	0°	90°	0°	90°	0°	90°	0°	90°	0°	90°	0°	90°		
350	10	189	165	227	204	266	243	305	281	344	320	383	359	422	398	499	476	577	553	35	56
	20	148	101	187	139	226	178	265	217	303	256	342	295	381	334	459	411	537	489	70	112
	30	108	36	146	75	185	114	224	153	263	192	302	231	341	269	418	347	496	425	106	168
	40	-	-	106	11	145	50	184	89	222	127	261	166	300	205	378	283	455	360	141	224
	50	-	-	-	-	-	-	143	24	182	63	221	102	260	141	337	218	415	296	176	280
	60	-	-	-	-	-	-	-	-	-	-	-	180	38	219	77	297	154	374	232	211
600	10	320	279	386	345	452	411	518	477	584	543	650	609	716	675	848	807	980	939	60	96
	20	251	169	317	235	383	301	449	367	515	433	581	499	647	565	779	697	911	829	121	192
	30	181	59	247	125	313	191	379	257	445	323	511	389	577	455	709	587	841	719	181	287
	40	-	-	178	15	244	81	310	147	376	213	442	279	508	345	640	477	772	609	241	383
	50	-	-	-	-	-	-	241	37	307	103	373	169	439	235	571	367	703	499	302	479
	60	-	-	-	-	-	-	-	-	-	-	-	303	59	369	125	501	257	633	389	362
950	10	481	427	579	525	677	623	775	721	873	819	971	917	1069	1015	1265	1211	1461	1407	77	121
	20	385	276	483	374	581	472	679	570	777	668	875	766	973	864	1169	1060	1365	1256	155	242
	30	288	125	386	223	484	321	582	418	680	516	778	614	876	712	1072	908	1268	1104	232	363
	40	-	-	289	71	387	169	485	267	583	365	681	463	779	561	975	757	1171	953	309	484
	50	-	-	-	-	-	-	389	116	487	214	585	312	683	410	879	606	1075	802	387	605
	60	-	-	-	-	-	-	-	-	390	63	488	161	586	259	782	455	978	651	464	726
1600	10	808	710	972	874	1136	1038	1300	1202	1465	1367	1629	1531	1793	1695	2122	2023	2450	2352	129	207
	20	647	450	811	615	975	779	1139	943	1304	1107	1468	1271	1632	1436	1960	1764	2289	2093	258	415
	30	486	191	650	355	814	520	978	684	1142	848	1307	1012	1471	1176	1799	1505	2128	1833	387	622
	40	-	-	489	96	653	260	817	425	981	589	1146	753	1310	917	1638	1246	1967	1574	516	830
	50	-	-	-	-	-	-	656	165	820	330	984	494	1149	658	1477	986	1806	1315	644	1037
	60	-	-	-	-	-	-	-	-	659	70	823	234	988	399	1316	727	1644	1056	773	1244
2500	10	1276	1133	1530	1388	1785	1642	2039	1896	2294	2151	2548	2405	2803	2660	3312	3169	3820	3678	180	295
	20	1050	765	1305	1019	1559	1274	1814	1528	2068	1783	2323	2037	2577	2292	3086	2801	3595	3309	361	589
	30	825	397	1079	651	1334	905	1588	1160	1843	1414	2097	1669	2352	1923	2860	2432	3369	2941	541	884
	40	-	-	854	283	1108	537	1363	792	1617	1046	1871	1301	2126	1555	2635	2064	3144	2573	722	1178
	50	-	-	-	-	883	169	1137	423	1391	678	1646	932	1900	1187	2409	1696	2918	2205	902	1473
	60	-	-	-	-	-	-	911	55	1166	310	1420	564	1675	819	2184	1327	2693	1836	1083	1768
4000	10	2063	1846	2476	2259	2889	2672	3302	3085	3715	3498	4128	3911	4541	4324	5367	5150	6193	5976	299	473
	20	1690	1255	2103	1668	2516	2081	2929	2494	3342	2907	3755	3320	4168	3733	4994	4559	5820	5385	598	945
	30	1316	664	1729	1077	2142	1490	2555	1903	2968	2316	3381	2729	3794	3142	4620	3968	5446	4794	896	1418
	40	943	73	1356	486	1769	899	2182	1312	2595	1725	3008	2138	3421	2551	4247	3377	5073	4203	1195	1891
	50	-	-	-	-	1395	309	1808	722	2221	1135	2634	1548	3047	1961	3873	2787	4699	3613	1494	2363
	60	-	-	-	-	-	-	1435	131	1848	544	2261	957	2674	1370	3500	2196	4326	3022	1793	2836

PE0025 - PE600

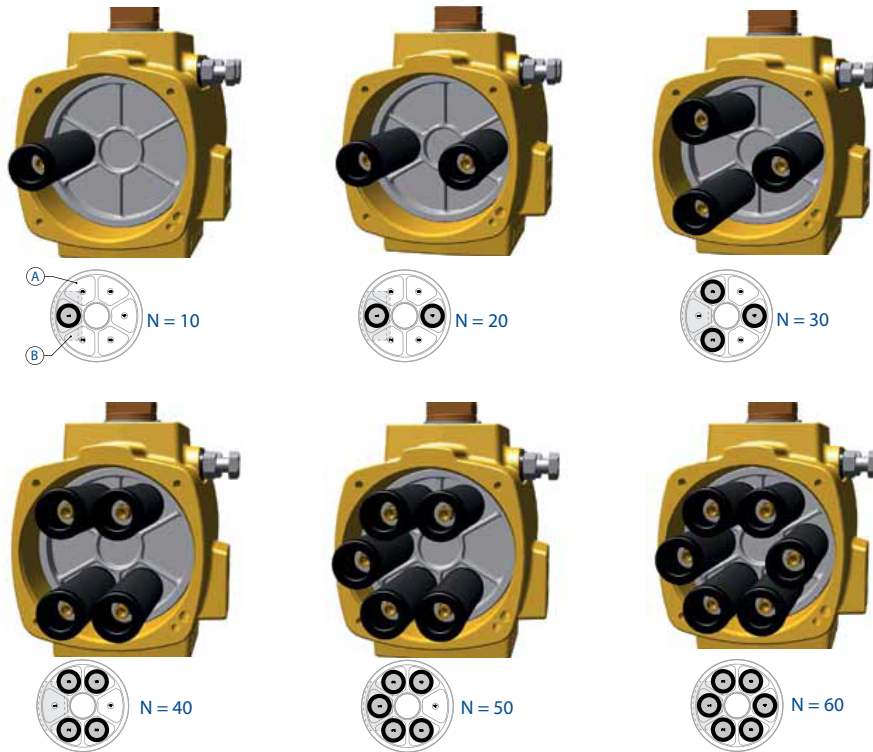

PE0950 - PE4000

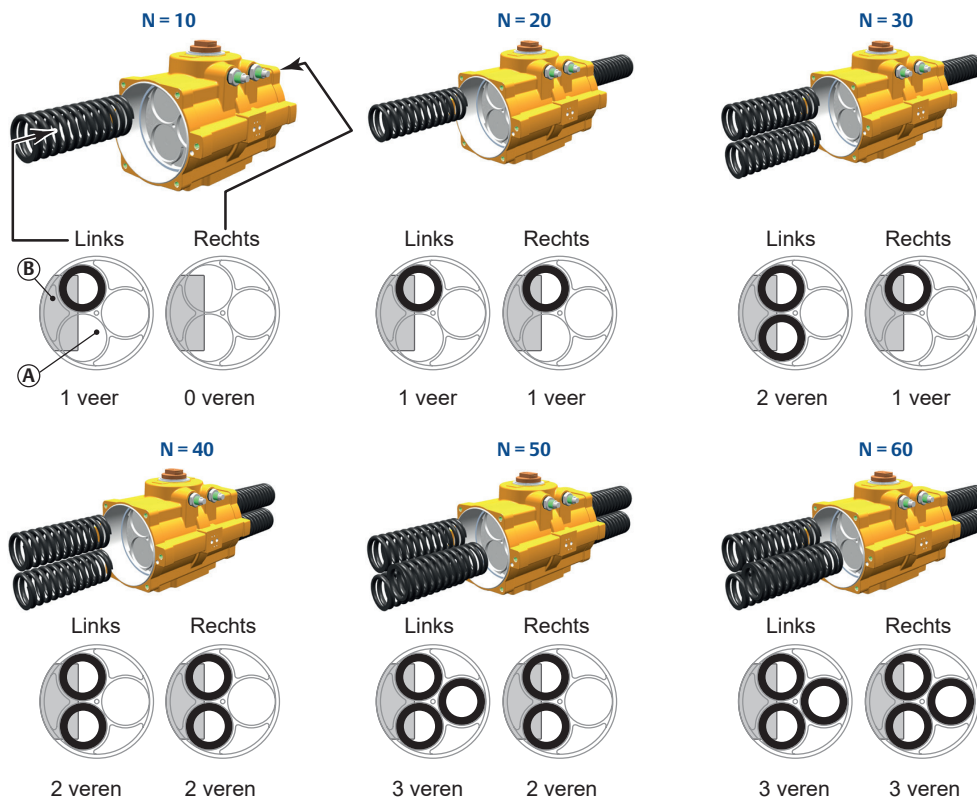

A: Bovenaanzicht zuiger
 B: Positie van kamwiel

Wijzigingen voorbehouden

TYPE	Duur cyclus in seconden			
	Enkelwerkend		Dubbelwerkend	
	Perslucht A-port	Veerretour	Perslucht A-port	Perslucht B-port
12	0,4	0,4	0,4	0,4
25	0,5	0,4	0,5	0,4
40	0,6	0,5	0,6	0,5
65	0,7	0,5	0,6	0,6
100	0,8	0,6	0,8	0,7
150	1,0	0,8	0,9	0,8
200	1,3	0,9	1,0	1,0
350	1,9	1,3	1,4	1,5
600	3,2	1,9	2,2	2,2
950	6,6	2,2	2,4	2,0
1600	10,6	3,5	3,6	3,3
2500	16,9	5,7	5,8	5,2
4000	29,1	9,2	9,2	9,0

TESTOMSTANDIGHEDEN:

1. Capaciteit magneetventiel: 0.6m³/h
2. leidingdiameter: 6 mm
3. Medium: Zuivere lucht
4. Perslucht druk: 5.5 bar
5. Belasting: Gemiddelde belasting
6. Slag: 90°
7. Temperatuur: Kamertemperatuur

TYPE	Volumes actuatoren		
	Max. volume (liter)		
	Centrale kamer	Kamer eindkap	Verplaatst volume
12	0,05	0,06	0,04
25	0,14	0,20	0,08
40	0,26	0,37	0,15
65	0,40	0,56	0,22
100	0,60	0,90	0,30
150	1,00	0,80	0,50
200	1,30	1,00	0,70
350	2,10	1,90	1,20
600	3,60	3,30	2,10
950	4,90	4,60	3,20
1600	7,90	7,30	5,40
2500	12,60	11,90	8,30
4000	21,70	19,00	13,50

TYPE	Verbruik per slag (liter)					
	Uitgaande slag			Ingaande slag		
	2 bar	4 bar	8 bar	2 bar	4 bar	8 bar
12	0,14	0,24	0,44	0,16	0,28	0,52
25	0,36	0,46	1,20	0,48	0,88	1,70
40	0,67	1,20	2,20	0,89	1,60	3,10
65	1,02	1,80	3,40	1,30	2,40	4,70
100	1,50	2,70	5,00	2,00	3,80	7,20
150	2,40	4,30	8,10	2,10	3,60	6,70
200	3,20	5,70	11,00	2,80	4,90	9,10
350	5,50	9,80	18,00	5,00	8,80	16,00
600	9,40	17,00	31,00	8,70	15,00	28,00
950	13,00	23,00	43,00	12,00	22,00	40,00
1600	21,00	37,00	69,00	20,00	35,00	64,00
2500	34,00	59,00	109,00	32,00	56,00	104,00
4000	57,00	100,00	187,00	52,00	89,00	165,00

Volume centrale kamer
Enkelwerkend en dubbelwerkend

Volume kamer eindkap
Dubbelwerkend

