

ALGEMENE KENMERKEN:

- Tweedelig huis - vlottende kogel - volle doorlaat - niet-uitdrukbare spindel
- Anti-static device volgens BS 5351, ISO 7121 en NF E29-470
- Drukvereffeningsboring (standaard= 5 mm) in de bovenzijde van de kogel voorkomt overdruk in de ruimte tussen de kogel en het huis
- Alle afsluiters voldoen aan de TA Lüft-vereisten
- Max. temperaturen: -29°C ~ 230°C (AIT) en -50°C ~ 230°C (IIT)

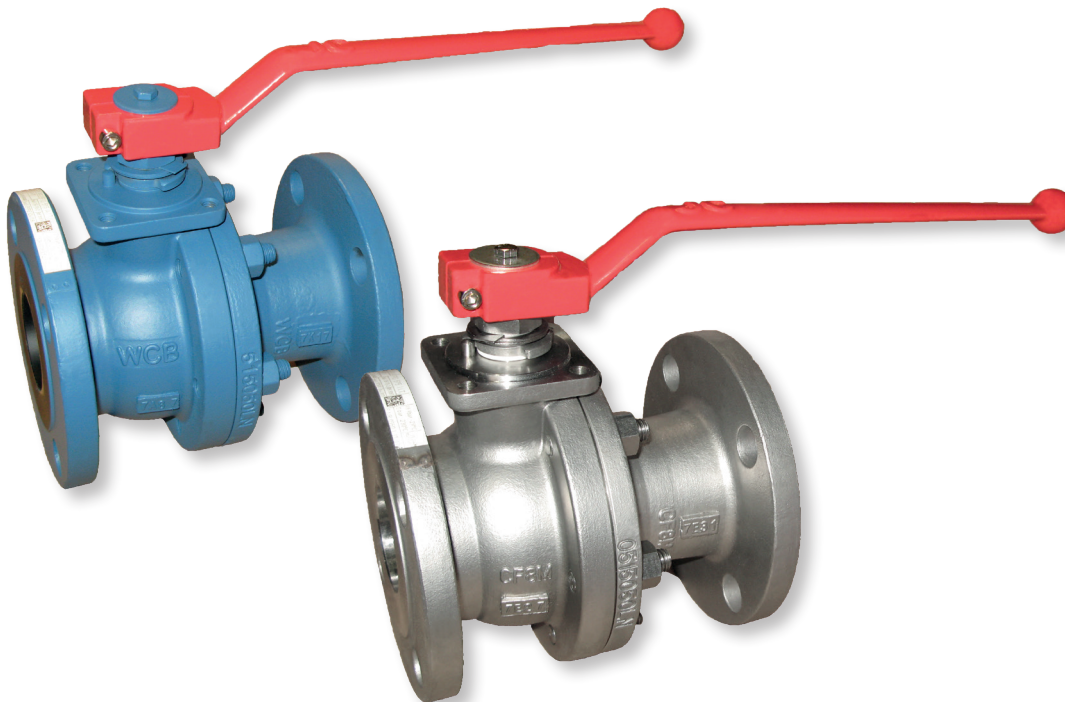

Fire safe tested



ONTWERP	
Kogelkraan	API 6D
Huis	ASME VIII Div.1
Laagdikte	ASME B16.34
Flenzen	ASME B16.5 Raised face
Inbouwlengte	ASME B16.10 Long pattern
Opbouwflens	ISO 5211
Afwerking bescherm laag	MSS SP 55
Markering	API 6D, CE-PED
TESTEN EN CERTIFICATEN	
Kwaliteit	ISO 9001, API 6D, CE-PED
Fire Safe certificaten	API 6FA, ISO 10497, API 607
Druktest	API 598, API 6D
Fugitive emissions	ISO 15848, API 641
TA-Luft	VDI 2440
SIL	Level 3 IEC 61508
Andere	ISO 14001, ATEX, EN13774

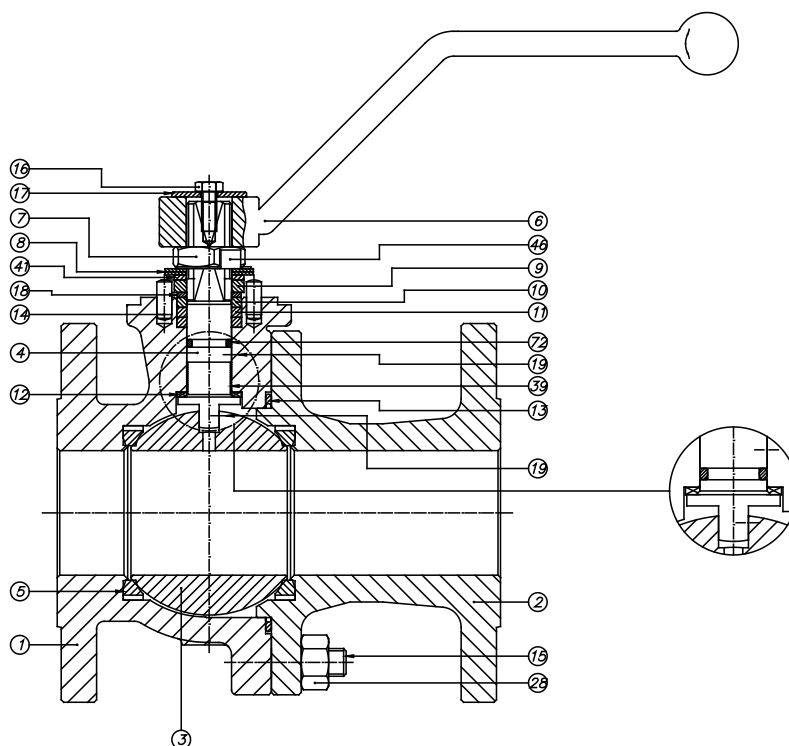

Pos.	Omschrijving	Materialen	
		AIT	IIT
1	Huis	A 216 Gr. WCB (C≤ 0,25%)	A 351 Gr. CF8M
2	Aansluitflens	A 216 Gr. WCB (C≤ 0,25%)	A 351 Gr. CF8M
3	Kogel	A 351 Gr. CF8M (DN 15 : 25 A 479 Tp.316)	
4	Spindel	F51	
5	Zitting	PTFE	
6	Hendel	A 216 Gr. WCB	
7	Spindelmoer	Staal, verzinkt	AISI 303
8	Schotelveer	Staal	Roestvast staal A666 TP.301
9	Stopplaat	Staal	AISI 304
10	Pakkingdrukker	AISI 303	AISI 316
11	Pakking	Grafiet	
12	Glijring	25% G.F. PTFE	
13	Huisafdichting	AISI 316L + PTFE + grafiet	
14	Stop	Staal, verzinkt	Roestvast staal
15	Bout (DN 15)	Staal	A 193 Gr. B8M
16	Bout	DIN 933 A2 - 70	
17	Rondel	AISI 303	AISI 304
18	Rondel	25% G.F. PTFE	
19	Antistatic device	Roestvast staal	
28	Moer (DN 20 t/m DN 200)	A 194 Gr. 2HM	A 194 Gr. 8M
39	Spindelgeleiding (DN 25 t/m DN 200)	25% G.F. PTFE	
41	Rondel (DN 40 t/m DN 200)	Staal	AISI 304
46	Rondel	AISI 304	
72	O-ring	FKM	
89	Identificatieplaat	Roestvast staal	

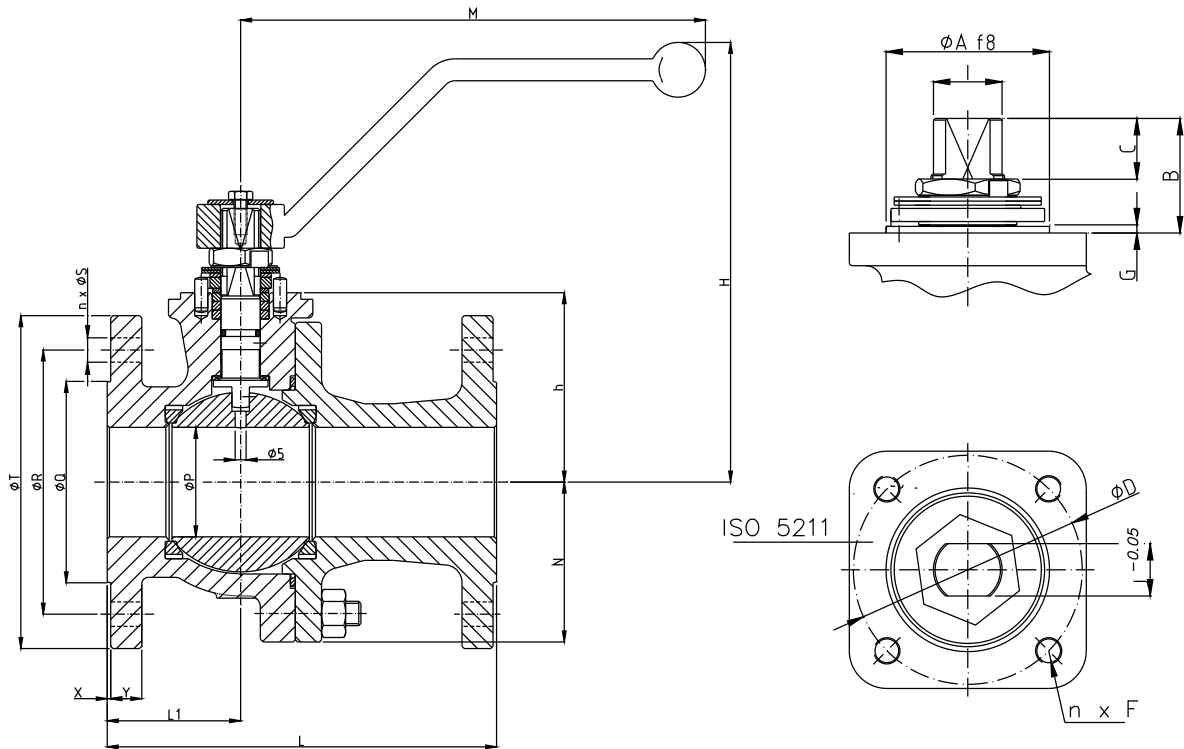

AFMETINGEN: (in mm)

DN	ØP	L	L1	ØQ	ØR	n x ØS	ØT	X	Y	h	N	H	M	Kg
15	15	108	47,0	34,9	60,3	4 x 15,9	90	2,0	8,0	46,0	-	111	164	2,0
20	20	117	50,0	42,9	69,8	4 x 15,9	100	2,0	8,9	53,0	-	118	164	3,0
25	25	127	52,0	50,8	79,4	4 x 15,9	110	2,0	9,6	58,0	-	130	164	3,5
40	40	165	65,0	73,0	98,4	4 x 15,9	125	2,0	12,7	76,0	-	148	213	8,0
50	50	178	61,0	92,1	120,7	4 x 19,1	150	2,0	14,3	83,5	-	155	213	11,0
65	65	190	75,0	104,8	139,7	4 x 19,1	180	2,0	15,9	97,0	-	169	348	16,0
80	80	203	78,5	127,0	152,4	4 x 19,1	190	2,0	17,5	111,0	-	207	445	23,0
100	100	229	90,0	157,2	190,5	8 x 19,1	230	2,0	22,3	133,0	120	232	495	38,0
150	151	394	174,0	215,9	241,3	8 x 22,2	280	2,0	23,9	183,0	168	299	698	88,0
200	203	457	200,0	270,0	298,4	8 x 22,2	345	2,0	27,0	233,0	208	353	868	155,0

OPBOUWFLENS: (in mm)

DN	ISO	ØA	B	C	ØD	n x F	G	I	J
15	F05	35	11,2	5,0	50	4 x M6	1,5	M12x1,5	9
20	F05	35	14,7	8,5	50	4 x M6	1,5	M12x1,5	9
25	F05	35	22,7	9,5	50	4 x M6	1,5	M12x1,5	9
40	F07	55	41,5	18,3	70	4 x M8	3,0	M18x1,5	13
50	F07	55	41,5	18,3	70	4 x M8	3,0	M18x1,5	13
65	F07	55	44,0	18,6	70	4 x M8	3,0	M22x1,5	16
80	F10	70	44,5	18,6	102	4 x M10	3,0	M25x1,5	18
100	F10	70	56,5	27,8	102	4 x M10	3,0	M28x1,5	20
150	F12	85	68,0	37,1	125	4 x M12	3,0	M40x2	29
200	F14	100	72,0	36,5	140	4 x M16	4,0	M45x2	32

DRUK-TEMPERATUURDIAGRAMMA:

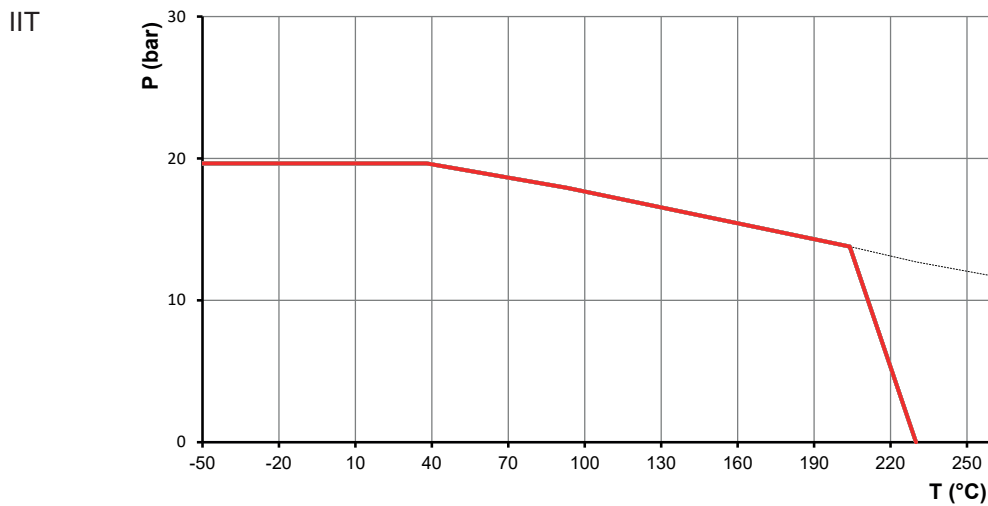
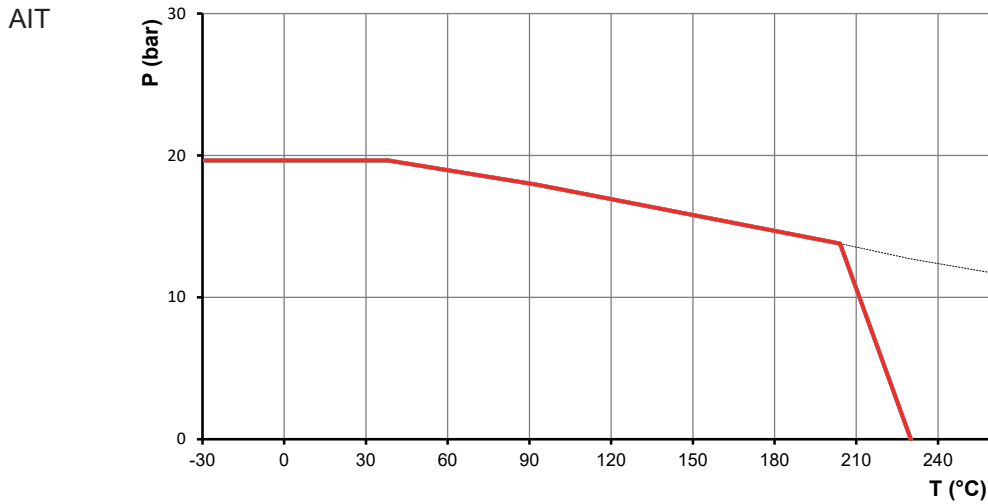

DRAAIMOMENT: (in Nm)

DN	150 Lbs
	Verschilddruk
	20 bar
15	9
20	13
25	17
40	30
50	43
65	66
80	102
100	150
150	326
200	729

Kv-WAARDE: (in m³/h)

DN	Kv-waarde
15	20
20	40
25	75
40	170
50	270
65	550
80	1.000
100	1.650
150	4.200
200	9.000

Wijzigingen voorbehouden