

ALGEMENE KENMERKEN:

- Kogelkraan met volle doorlaat, huis in roestvrijstaal, DN 10 - DN 200
- Voor tussenbouw tussen flenzen PN 16/40 (DN 10 - DN 50), PN 16 (DN 65 - DN 200)
- Met getapte gaten volgens EN 1092-1 / DIN 2501
- Anti-static device
- Niet-uitdrukbare spindel
- Opbouwflens volgens ISO 5211, DIN 3337

FIGUUR:

10NFIITA: roestvrijstaal ASTM A351 CF8

10NFIITB: roestvrijstaal ASTM A351 CF8M

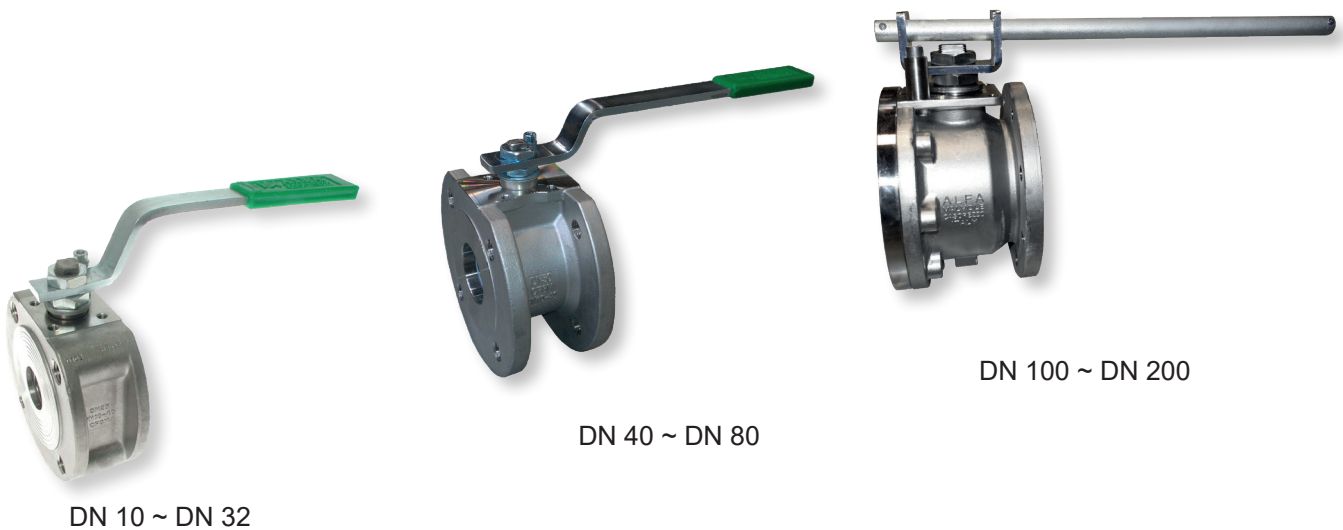

ONTWERP	
Flenzen	DIN 2501, EN 1092-1
Opbouwflens	ISO 5211, DIN 3337
Markering	EN 19, CE-PED
TESTEN EN CERTIFICATEN	
Kwaliteit	ISO 9001, CE-PED
Druktest	EN 12266
Andere	ATEX: II 2 GD c T6 X, TA Lüft

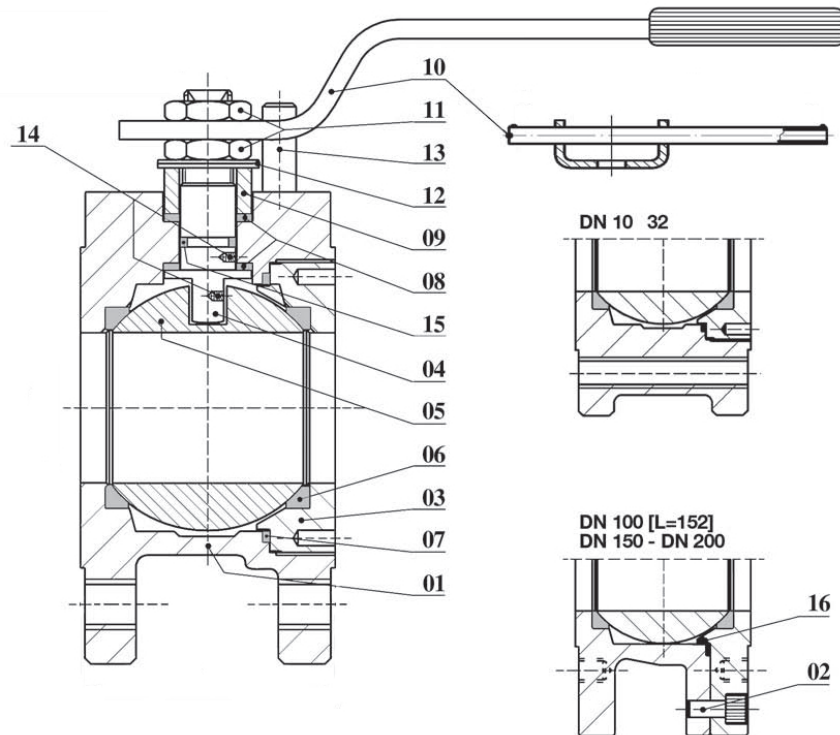

Pos.	Omschrijving	Materialen	
		IITA	IITB
1	Huis	ASTM A351 CF8	ASTM A351 CF8M
2	Schroef	A4-40 (AISI 316)	
3	Tegenflens	ASTM A351 CF8	ASTM A351 CF8M
4	Spindel	ASTM A182 316/316L	
5	Kogel	ASTM A351 CF8	ASTM A351 CF8M
6	Zitting	TFM	
7	Huisafdichting	PTFE	
8	Spindelafdichting	PTFE	
9	Stopbuspakking	ASTM A479 F304	
10	Hendel	Fe37 UNI 7070, verzinkt	
11	Moer en tegenmoer	A4-40 (AISI 316)	
12	Schotelveren	AISI 316	
13	Stop	AISI 316	
14	Antistatic device	AISI 316	
15	O-ring op de spindel	Viton	
16	O-ring op het huis	PTFE	

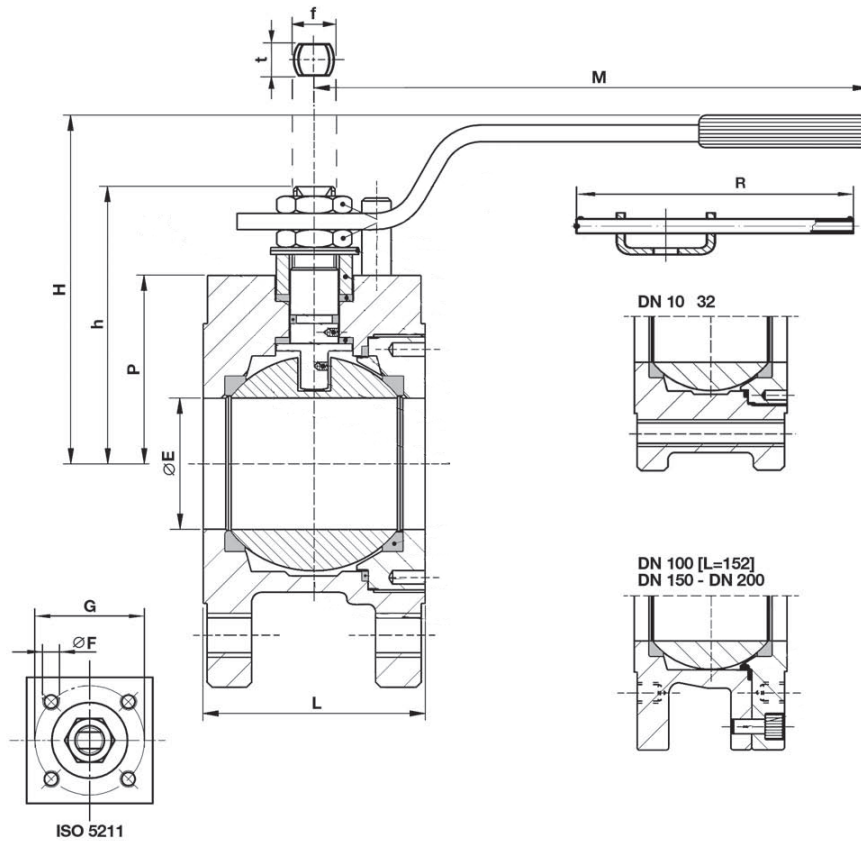
AFMETINGEN: (mm)

DN	Ø	ØE	L	M	R	H	h	P	f	t	ISO 5211	ØF	G	kg
10	3/8"	14	36	150	-	84	52	33,0	10	6	F03	M5	36	1,2
15	1/2"	14	36	150	-	84	52	33,0	10	6	F03	M5	36	1,2
20	3/4"	19	39	150	-	87	54	36,0	10	6	F03	M5	36	1,7
25	1"	24	43	185	-	95	69	43,0	12	8	F03	M5	36	2,0
32	1 1/4"	29	51	185	-	99	72	48,0	12	8	F03	M5	36	3,0
40	1 1/2"	38	63	275	-	118	95	63,0	16	10	F05	M6	50	4,5
50	2"	48	83	275	-	126	101	68,5	16	10	F05	M6	50	5,8
65	2 1/2"	64	107	380	-	143	122	82,0	22	14	F07	M8	70	10,0
80	3"	76	120	380	-	149	127	88,5	22	14	F07	M8	70	13,0
100	4"	95	152	440	500	185	151	103,0	30	18	F10	M10	102	22,0
125	5"	118	180	440	500	200	167	120,0	30	18	F10	M10	102	30,0
150	6"	152	243	-	800	273	220	153,0	45	30	F14	M16	140	69,0
200	8"	203	314	-	800	322	270	200,0	52	30	F14	M16	140	132,0

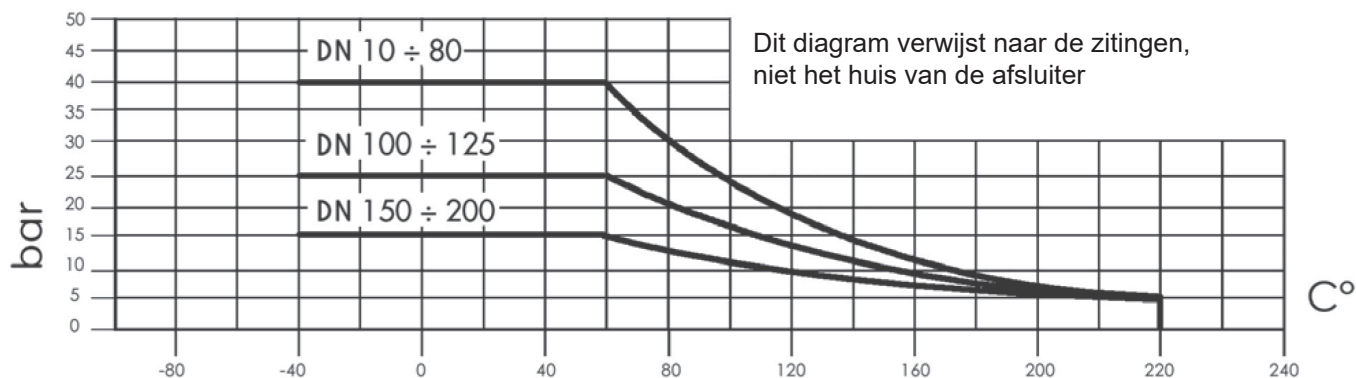
DRUK-TEMPERATUURDIAGRAMMA:

DRAAIMOMENT: (Nm)

DN	Verschildruk	
	16 bar	40 bar
10	4	5
15	6	9
20	9	13
25	13	17
32	15	21
40	28	39
50	36	50
50X	36	50
65	64	-
80	77	-
100	127	-
125	153	-
150	319	-
200	509	-